

## MFSTR-SSXCLAD-316 Attachment System

Product Category	Cladding
Product Name	MFSTR-SSXCLAD
Material	316 Alloy Stainless Steel
Finish	N/A

### Geometric Properties

Depth (Assembled)	1.125 in
Design Thickness	0.1196 in
11 Gauge Tolerance	+/- .007 in
Yield stress, Fy	42.1ksi
Ultimate, Fu	84.1ksi

### Gross Section Properties of Full Section, Strong Axis

Cross section area (A)	0.630 in <sup>(2)</sup>
Member weight per foot of length	2.147 lb/ft
Moment of inertia (Ix)	0.738 in <sup>(4)</sup>
Radius of gyration (Rx)	1.082in
Section Modulus (Sx)	0.423 in <sup>(3)</sup>

### Gross Section Properties of Full Section, Weak Axis

Cross section area (A)	0.630 in <sup>(2)</sup>
Member weight per foot of length	2.147 lb/ft
Gross moment of inertia (Iy)	0.086 in <sup>(4)</sup>
Gross radius of gyration (Ry)	0.368 in
Section Modulus (Sy)	0.113 in <sup>(3)</sup>

### Effective Section Properties, Strong Axis

Moment of inertia for deflection (Ix)	0.706 in <sup>(4)</sup>
Section Modulus (Sx)	0.406 in <sup>(3)</sup>

### Effective Section Properties, Weak Axis

Moment of inertia for deflection (Iy)	0.083 in <sup>(4)</sup>
Section Modulus (Sy)	0.107 in <sup>(3)</sup>

### Product Data & Ordering Information:

Stock length	8'-0" long pieces
Packaging	Custom Pallet
Packaging weight	Custom

### ASTM & Code Standards:

- Stainless sheet steel meets or exceed requirements of ASTM A240/A240M
- SDS Information is available by contacting [zclip@monarchmetal.com](mailto:zclip@monarchmetal.com)

### Allowable Spans for Brackets

- Allowable spans for brackets will depend upon the conditions of the installation including, but not limited to, the substrate the rails are attaching to, the panel composition, the fasteners selected and the wind conditions. Please consult a structural engineer for additional information.
- Monarch Metal provides typical as well as thermally isolated substructure.

### Sustainability Credits:

For more details and LEED letters contact 631-750-3000

**LEED 2009 Credit MR 2& MR 4** –Stainless Steel products are 100% recyclable and have a average recycled content of 75 - 85% (SSINA <http://www.ssina.com/leed.htm>)

## MFSTR-SSXCLAD-316 Attachment System

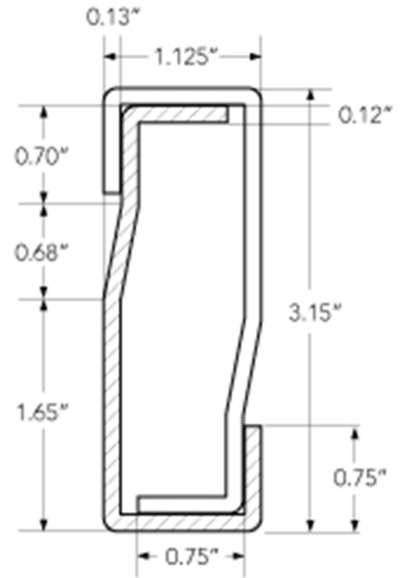

### Used in rain screen attachment applications:

- Concealed installation of stone, fiber cement, HPL or fiber concrete panels
- Highly corrosion resistant
- Adjust system for panel height after attachment

### Project Information

Name:  
Address:

### Contractor Information

Name:  
Contact:  
Phone:

### Architect Information

Name:  
Contact:  
Phone: