

MONARCH Z CLIP Load Testing Summary



MONARCH
METAL FABRICATION

INTRODUCTION

One of the most frequent requests at Monarch Metal is for the load bearing information of our Monarch Z Clip Systems for installing panels, signs and art work. In all of the internal tests Monarch has done, it has been the screws holding the Monarch Clips that fail and not the Monarch Clip itself. However, the question has come up frequently enough that we engaged Qualtim, Inc., a third party independent laboratory, to perform testing on the clips.

TESTING DESIGN

As part of the test design, we set out with the goal to understand what the mode of failure and relative strength would be for the most common installations. To understand the mode of failure, one has to start with the elements that are important to determining the strength of the system. The 5 elements to consider are:

- 1) The mounting surface for the continuous lengths.
For example, will they be mounted to wood studs or metal studs?
Will there be blocking? Drywall?
- 2) What screw is being used to mount the continuous length?
Is it a sheet metal screw, a wood screw or a specialty screw?
How long is the screw? What is the diameter?
- 3) Which Monarch Clip is being used? Stainless Steel or Aluminum?
- 4) What is the material, thickness and size of the item being hung?
- 5) What screw is being used to mount the shorter panel clips to the back of the panel?

Figure 1. Monarch Z Clip Cut Through Drawing

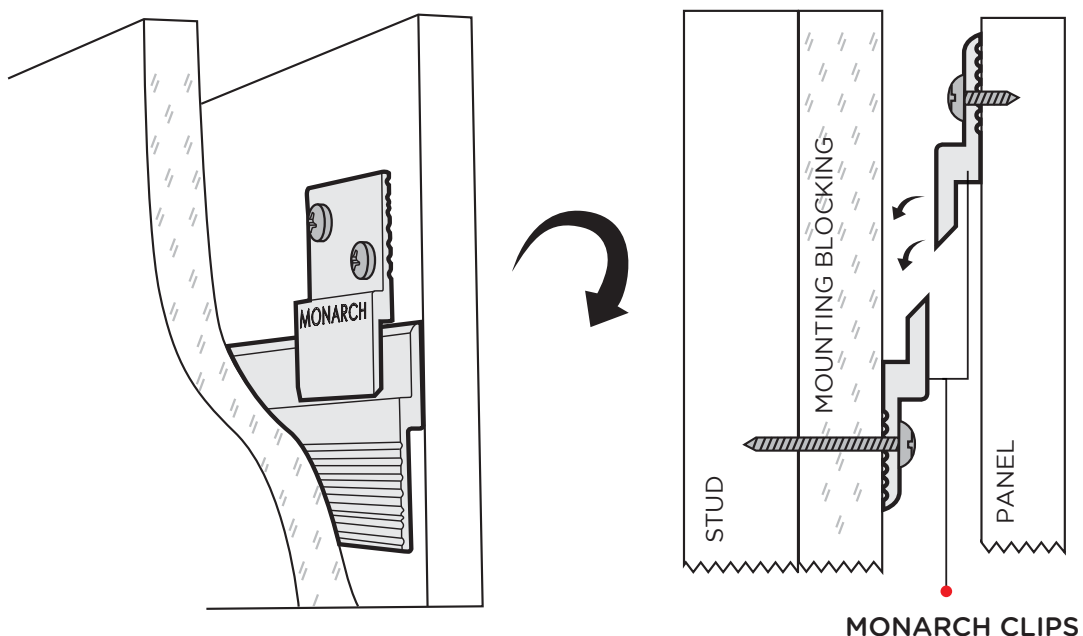

We only give all of these questions to illustrate the number of variables to control for when testing and show the difficulty of designing an appropriate test. These variables do not even include the typical variables to consider such as the environment of the installation as well as the direction of the force (assumed to be entirely in shear in this testing.)

To try to address the widest cross section of applications, we designed three different tests.

- 1) The first test was designed to test the load at which the Monarch Z Clips pull out from the backside of the panel.
- 2) The second test was designed to test the load at which the system would fail in a standard installation of a ¾" thick MDF veneered panel onto steel studs with ¾" OSB blocking.
- 3) The third test was designed to test the load at which the system would fail in a standard installation of a ¾" thick MDF veneered panel onto wood studs with ½" gypsum sheathing.

STANDARD INSTALLATION

A standard installation of a ¾" Thick, 48" Wide x 96" Tall MDF panel, involves mounting three different continuous lengths along the wall parallel to the floor. The continuous lengths would be spaced approximately 30" apart. The continuous lengths are fastened to studs at a minimum of every 16" on center with the appropriate screw. Our testing was done with 22 Gauge Metal Studs and Wood Studs and the results would not apply for weaker substrates. Installers often use ¾" blocking in front of the wall to allow for added fasteners every 8" on center along the wall. Along the panel, installers would typically use 12 panel clips on the back of the panel; 4 panel clips at each height to interlock with each of the 3 continuous lengths. These clips would be spaced 12 to 15 inches apart and fastened to the back of the panel with (2) #8x ¾" Pan Head Deep Thread Screws for a total of 24 screws in a typical panel installation.

Test Set-up 1 - Shear Test of Panel Clips

The first test formation was designed to test the shear strength of the panel clips mounted to the rear side of the panel. The continuous lengths were prevented from failing by reinforcing the wood studs with SPF 2 x 4 blocking and fastening the continuous length to the blocking every 4 inches.

Monarch Z-Clip Shear Test 1a-c

- Test Purpose: Ultimate load capacity of MF375-2" Z-Clip in ideal installation
- 16" On-Center SPF stud spacing with SPF intermediate blocking between studs
- ¾" MDF Panel
- 2" x 4" SPF intermediate blocking
- (12) Monarch MF375-2" Z-Clip (3 Rows of 4 Clips) - Attached to MDF at 14" o.c. with #8 x ¾" Coarse Thread Screws
- (3) Monarch MF375 Z-Clip 60" (Continuous-Length) cut to 49-1/2" - attached to stud and intermediate blocking with #8 x 2" Sheet Metal Screws

Figure 2. Monarch Test Set-up 1 - Strength of Clip Attached to Panel

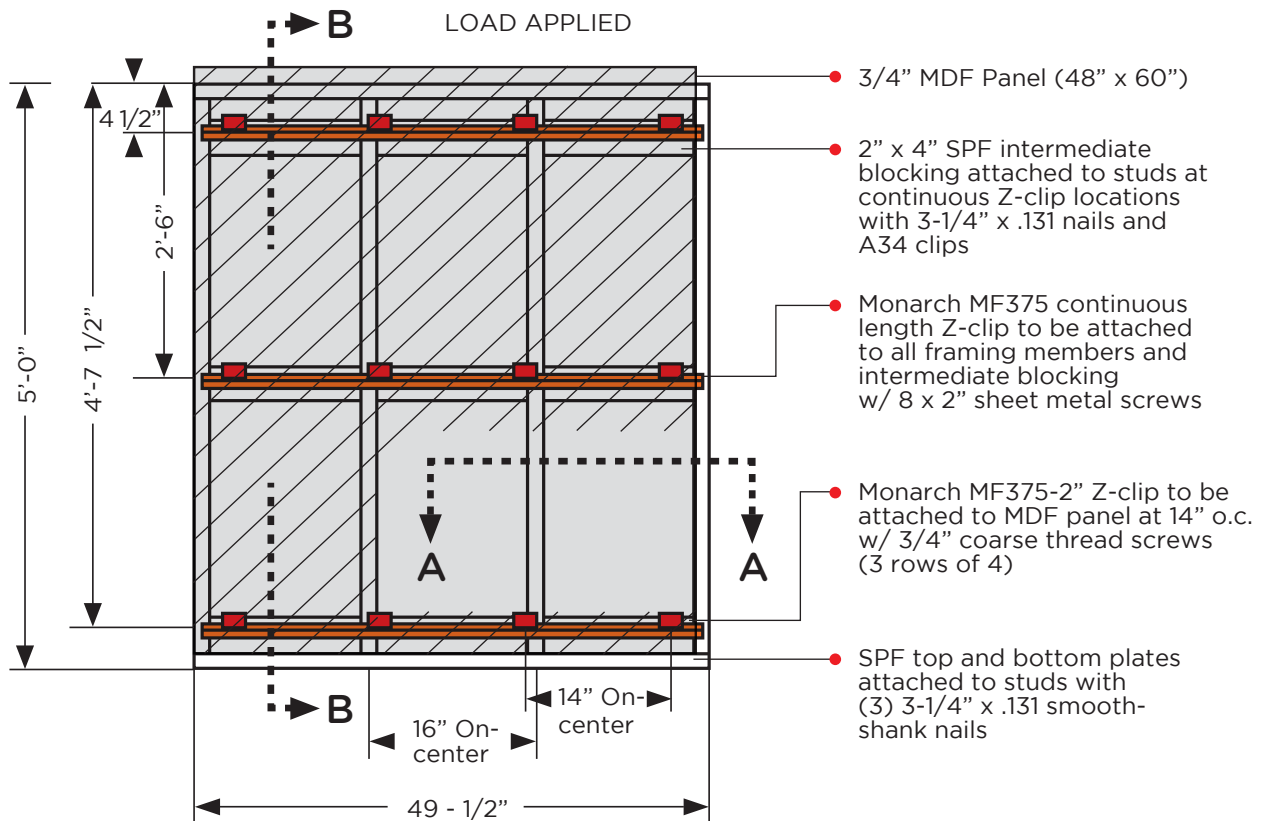

FRONT ELEVATION

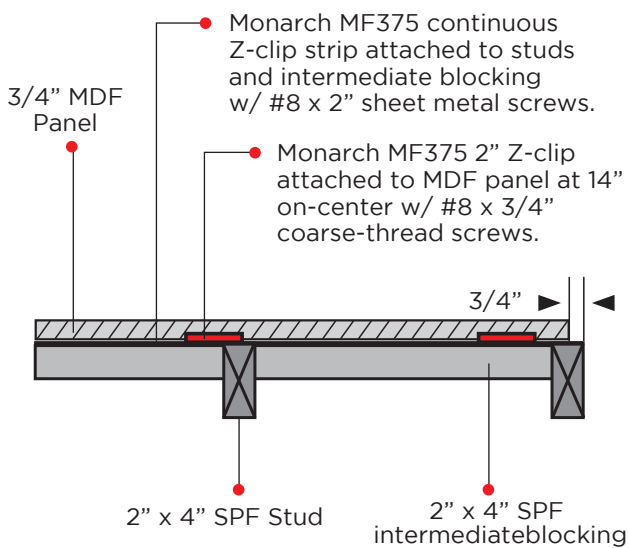

SECTION 'A-A'

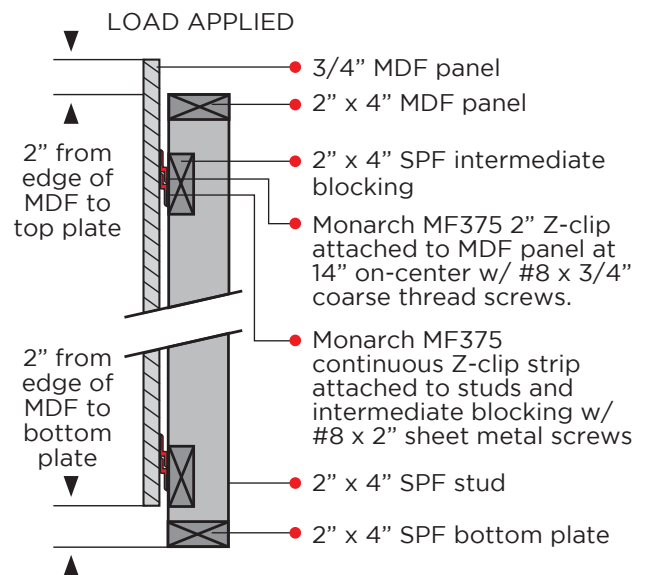

SECTION 'B-B'

Figure 3: Test Setup 1 - Wall Mount



Figure 4: Test Setup 1 - Panel as Mounted



The table below describes the specifics of the test conditions as well as the results of the testing.

Figure 5: Test Setup 1 - Testing Summary

Test Description	Wood Studs with intermediate blocking and track fasteners at 4" o.c.
Stud Material	SPF Stud
Plate Material	SPF No. 2
Wall Mounting	(3) 48" Monarch MF375 Continuous Lengths
Screws Used	#8 x 2" Pan head sheet metal screws
# of screws	39
Sheathing	N/A
Panel Type	3/4" MDF
Panel Mounting	(12) Monarch MF375 Z Clips
Screws Used	#8 x 3/4" Pan Phillips deep thread screw
# of Screws	24
Mode of Failure	Fasteners in MDF failed in withdrawal & the 2" clips wedged behind continuous length

TEST	Max Load	Deflection at Max Load	Load at Given Deflection				Lateral Load Between Sheathing & Clip (lbs)		Lateral Load Between Track-Blocking & Blocking-Stud (lbs)		
			0.0625	0.1250	0.1875	0.2500	Max Test Load	Calculated Strength	Max Test Load	Calculated Strength	
										Track-Blocking	Blocking-Stud
1a	8,352	0.391	1,671	3,894	5,276	6,542	348	348	214	N/A	694
1b	8,067	0.354	1,346	3,087	5,157	6,705	336	348	207	N/A	694
1c	8,536	0.344	1,009	3,343	5,646	7,289	356	348	219	N/A	694
Average	8,318	0.363	1,342	3,441	5,360	6,846	347	348	213	N/A	694

Test Set-up 1 - Conclusion

In these conditions where we controlled the set up to test only the Monarch Clips attached to the rear side of the panels, the panel failed at an average of 8,318 pounds. There were (24) #8 x 3/4" pan phillips deep thread screws securing the (12) Monarch MF375 Clips to the back of the panel. The load per screw where shear failure occurred was 347 pounds. It is important to note that the Monarch Z Clip's themselves did not fail at this load.

Test Set-up 2 - Standard Installation on Metal Studs with Blocking

The second test set-up was designed to test the shear strength of the Monarch Z Clip System for wall cladding where the base mounting substrate is metal studs with blocking. Qualtim used 3/4" OSB for blocking for tests and drilled through the blocking at 16" on center to secure the continuous lengths to the metal studs.

Monarch Z-Clip Shear Test 1a-c

- Test Purpose: Ultimate load capacity of MF375 Z-Clip system in typical non-ideal installation
- 16" On-Center 22 gauge steel stud spacing on interior 3 studs - No intermediate blocking between studs
- 3/4" MDF Panel
- (12) Monarch MF375-2" Z-Clip (3 Rows of 4 Clips) - Attached to MDF at 14" o.c. with #8 x 3/4" Coarse Thread Screws
- (3) Monarch MF375 Z-Clip 48" (Continuous-Length) - Attached to stud through 3/4" x 8" OSB strips with #8 x 2" self-drilling sheet metal screws

Figure 6. Monarch Test Set-up 2 - Monarch Z Clip System in Metal Studs w/ Blocking

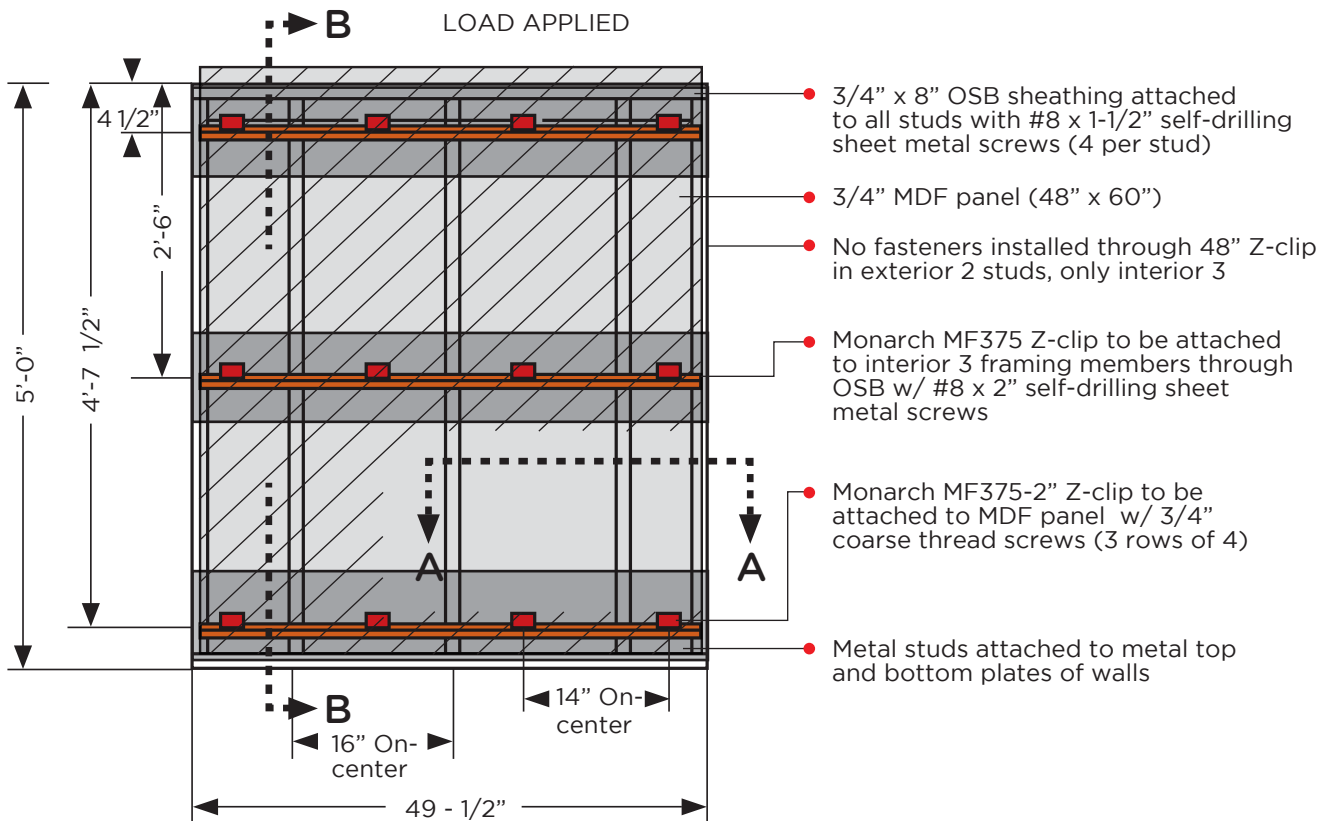

FRONT ELEVATION

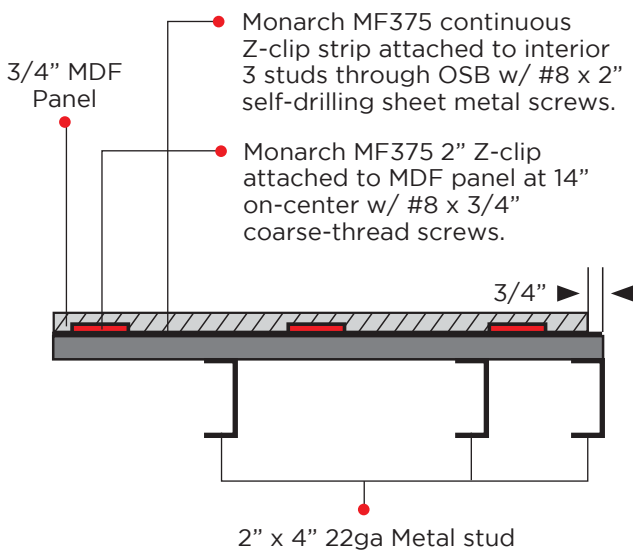

SECTION 'A-A'

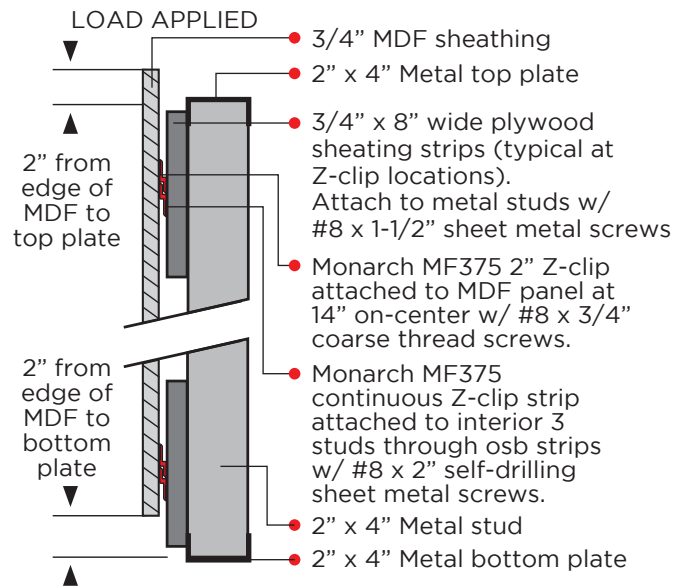

SECTION 'B-B'

Figure 7: Test Set-up 2 - Wall Mount



Figure 8: Test Set-up 2 - Panel Rear Side



The table below describes the specifics of the test conditions as well as the results of the testing.

Figure 9: Test Setup 2 - Testing Summary

Test Description	Studs with 3/4" OSB blocking. Continuous length fastened at 16" o.c.	
Stud Material	20 Ga. Steel	
Plate Material	20 Ga. Steel Equivalent	
Wall Mounting	(3) 48" Monarch MF375 Continuous Lengths	
Screws Used	#8 x 2" Pan head sheet metal screws	
# of screws	9	
Sheathing Type	3/4" OSB	
Panel Type	3/4" MDF	
Panel Mounting	(12) Monarch MF375 Z Clips	
Screws Used	#8 x 3/4" Pan Phillips deep thread screw	
# of Screws	24	
Mode of Failure	3/4" OSB Held track in plane while mounting screw rotated in stud. Rotation between clip and track caused failure in the clip screws in withdrawal. Panel bowed under load in both axi	

TEST	Max Load	Deflection at Max Load	Load at Given Deflection				Lateral Load Between Sheathing & Clip (lbs)		Lateral Load Between Track-Blocking & Blocking-Stud (lbs)		
			0.0625	0.1250	0.1875	0.2500	Max Test Load	Calculated Strength	Max Test Load	Calculated Strength	
										Track-Blocking	Blocking-Stud
2a	4,061	0.431	1,138	2,030	2,768	3,303	169	348	451	393	492
2b	4,383	0.513	1,376	2,286	2,954	3,568	183	348	487	393	492
2c	4,319	0.503	965	1,945	2,694	3,245	180	348	480	393	492
Average	4,254	0.482	1,159	2,087	2,805	3,372	177	348	473	393	492

Test Set-up 2 - Conclusion

In these conditions where we tried to recreate a typical installation of a 3/4" MDF panel using the Monarch Z Clip system on metal studs with plywood blocking, we found that the average panel failed at 4,254 pounds. The mode of failure was that the continuous length (as well as the panel) bowed and bent at high pressure, which had the effect of prying the screws holding the Monarch Z Clips to the back of the panel, forcing them to pull out. (24) #8 x 3/4" pan phillips deep thread screws were used to secure the (12) Monarch MF375 Clips to the back of the panel. The load per screw where shear failure occurred was 177 pounds. It is important to note that the Monarch Z Clip's themselves did not fail at this load.

Test Set-up 3 - Standard Installation on Wood Studs with Gypsum

The third test set-up was designed to test the shear strength of the Monarch Z Clip System for wall cladding where the base mounting substrate is SPF wood studs with 1/2" gypsum sheathing.

Monarch Z-Clip Shear Test 1a-c

- Test Purpose: Ultimate load capacity of MF375 Z-Clip system in typical non-ideal installation
- 16" On-Center SPF stud spacing on interior 3 studs - No intermediate blocking between studs
- 3/4" MDF Panel
- 1/2" Gypsum attached to wall with #6 x 1-1/4" drywall screws at 16:16 spacing
- (12) Monarch MF375-2" Z-clip (3 rows of 4 clips) - Attached to MDF at 14" o.c. with #8 x 3/4" coarse thread screws
- (3) Monarch MF375 Z-clip 48" (Continuous-Length) - Attached to stud through 1/2" Gypsum with #8 x 2" sheet metal screws

Figure 10. Monarch Test Set-up 3 - Monarch Z Clip System in Metal Studs with Blocking

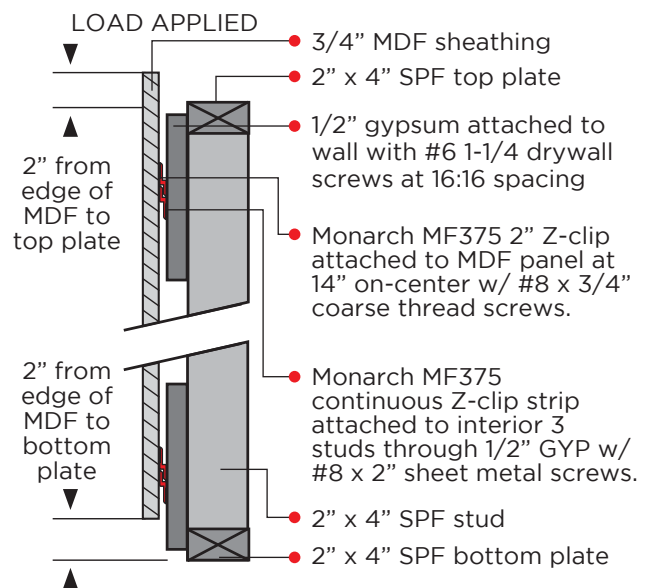
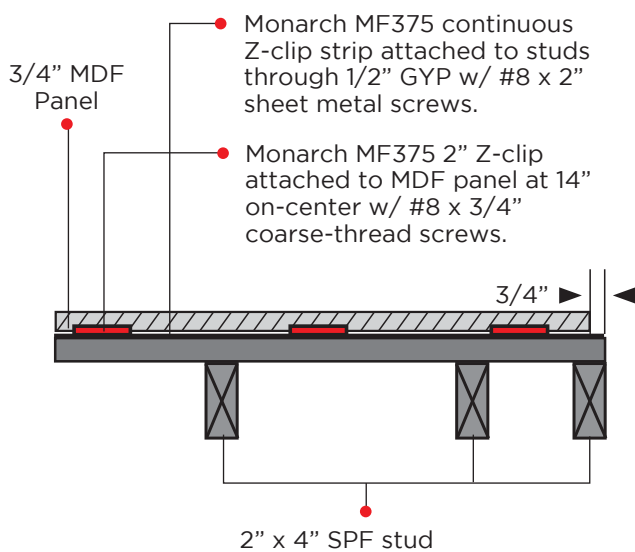
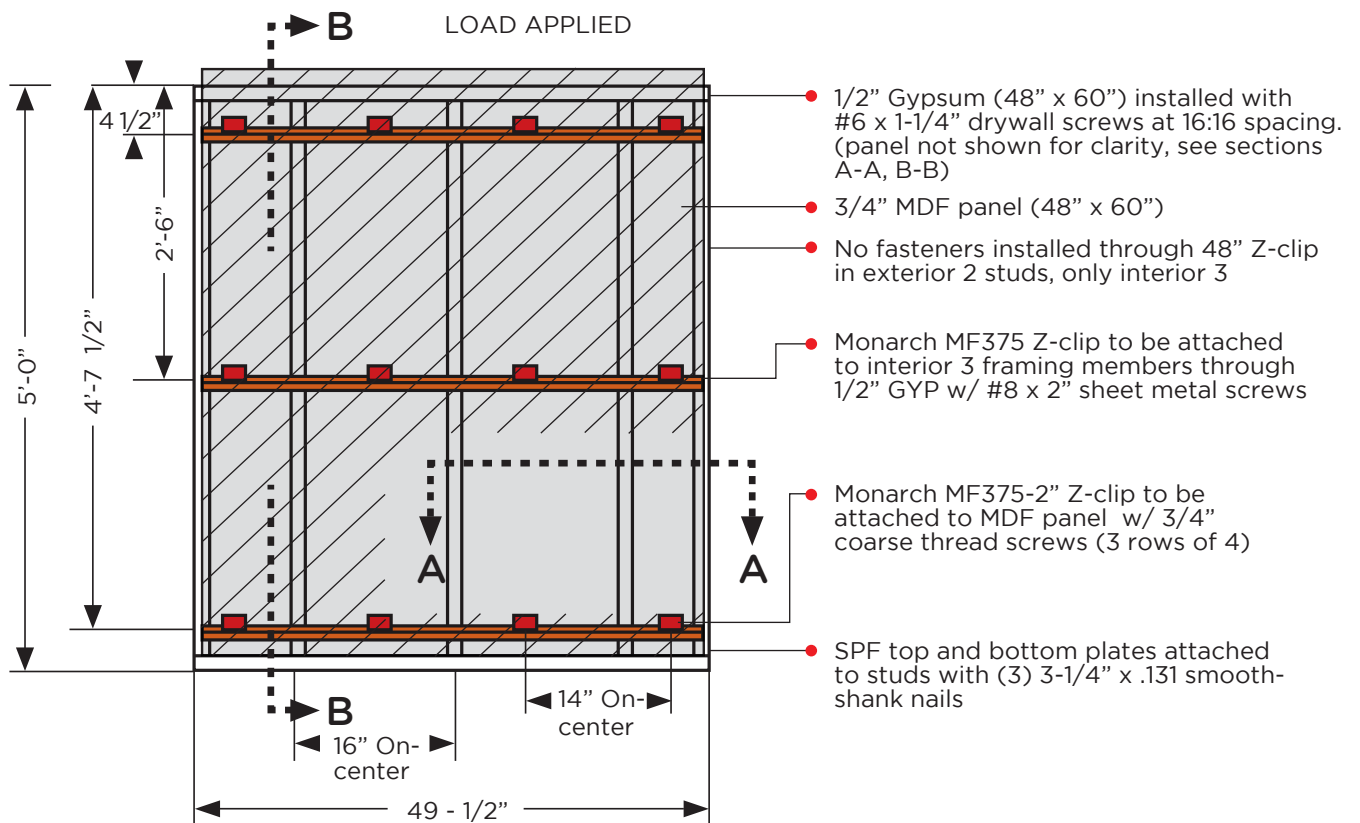

Figure 11: Test Set-up 3 - Wall Mount



Figure 12: Test Set-up 3 - Panel Rear Side (Failed)



The table below describes the specifics of the test conditions as well as the results of the testing.

Figure 13: Test Setup 3 - Testing Summary

Test Description	Wood studs with 1/2" gypsum sheathing
Stud Material	SPF Stud
Plate Material	SPF No. 2
Wall Mounting	(3) 48" Monarch MF375 Continuous Lengths
Screws Used	#8 x 2" Pan head sheet metal screws
# of screws	9
Sheathing Type	1/2" Gypsum
Panel Type	3/4" MDF
Panel Mounting	(12) Monarch MF375 Z Clips
Screws Used	#8 x 3/4" Pan Phillips deep thread screw
# of Screws	24
Mode of Failure	Continuous length track bent mounting screws and rotated down into gypsum. Fasteners in clips in MDF began to fall in withdrawal as panel clips rotated with wall. MDF panel bowed under load in both axis. Continuous length bent across length and clips wedged into the gypsum behind the track.

TEST	Max Load	Deflection at Max Load	Load at Given Deflection				Lateral Load Between Sheathing & Clip (lbs)		Lateral Load Between Track-Blocking & Blocking-Stud (lbs)		
			0.0625	0.1250	0.1875	0.2500	Max Test Load	Calculated Strength	Max Test Load	Calculated Strength	
										Track-Blocking	Blocking-Stud
3a	4,402	0.577	849	1,538	2,168	2,732	183	348	489	0	528
3b	3,700	0.463	1,054	1,862	2,472	2,969	154	348	411	0	528
3c	3,924	0.484	1,142	1,866	2,517	3,011	164	348	436	0	528
Average	4,009	0.508	1,015	1,755	2,386	2,904	167	348	445	0	492v

Test Set-up 3 - Conclusion

In these conditions where we tried to recreate a typical installation of a 3/4" MDF panel using the Monarch Z Clip system on SPF wood studs with gypsum sheathing, we found that the average panel failed at 4,009 pounds. The mode of failure was that the continuous length (as well as the panel) bowed and bent at high pressure, which had the effect of prying the screws holding the Monarch Z Clips to the back of the panel, forcing them to pull out. There were (24) #8 x 3/4" pan phillips deep thread black oxide screws securing the (12) Monarch MF375 Clips to the back of the panel. The load per screw where shear failure occurred was 167 pounds. It is important to note that the Monarch Z Clip's themselves did not fail at this load.

SUMMARY

Monarch conducted testing to determine the ultimate shear strength of a standard installation using the Monarch Z Clip system and determined that the system failed at between 3,700 to 4,401 pounds in the setup tested. In a panel installation, the Monarch Z Clip is only one element of five in the hanging system: (i) the material and thickness of the surface the panel is being mounted to, (ii) the screw used to fasten the Monarch Continuous length to the mounting surface, (iii) the Monarch Z Clip System used, (iv) the screw used to fasten the Monarch Clips to the back of the panel, and (v) the material and thickness of the panel. The testing indicated that in a standard installation, the weak point of the system was the screw holding the Monarch Clip to the back of the panel. The mode of failure was pull out of the screws securing the Monarch Clips to the back of the panel, as the continuous lengths bent across the length and wedged under the shorter panel clips.

DISCLAIMER:

The tested capacity of the clips as defined herein is merely intended to provide guidance for all end-users on the capacity that is available when #8 x $\frac{3}{4}$ " Pan Phillips Deep Thread screws are used to attach clips to MDF panels. This capacity has been developed through testing under a given set of testing conditions that represent typical installations. Decisions made, by the end user, with respect to capacities must take into account installation deviations from the tested application, accuracy of screw placement, any potential for over driving of the screws, panel misuse, improper panel or clip storage, panel and clip handling, etc. The final capacity to be used for any installation is the responsibility of the end-user.