

Monarch SPS Components - Interior Wall Panel System

Zero-Lift Installation for use with all common interior panel types. Including, but not limited to: High-Pressure Laminates (HPL), Wood, MDF, and Plywood.

Created By: amh	Approved By:	Sheet Size A	Sheet No. 1/15
Creation Date: 1/7/2025	Approval Date:	Scale	Rev 1

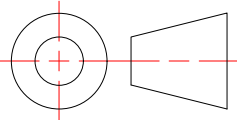

Weight:

Finish:



MONARCH
METAL INC.

PROPRIETARY AND CONFIDENTIAL

THE INFORMATION CONTAINED IN THIS DRAWING IS THE SOLE PROPERTY OF MONARCH METAL FABRICATION. ANY REPRODUCTION IN PART OR AS A WHOLE WITHOUT THE WRITTEN PERMISSION OF MONARCH METAL INC. IS PROHIBITED.

New York 1700 Ocean Ave Suite 2 Ronkonkoma NY 11779 Phone: (631) 750-3000	Nevada 1080 Linda Way, Unit 10 Sparks, NV 89431 Phone: (775) 415-0100	Texas 1330 Post & Paddock St., Suite 800 Grand Prairie, TX 75050 (945) 202-2700
---	---	--

monarchmetal.com

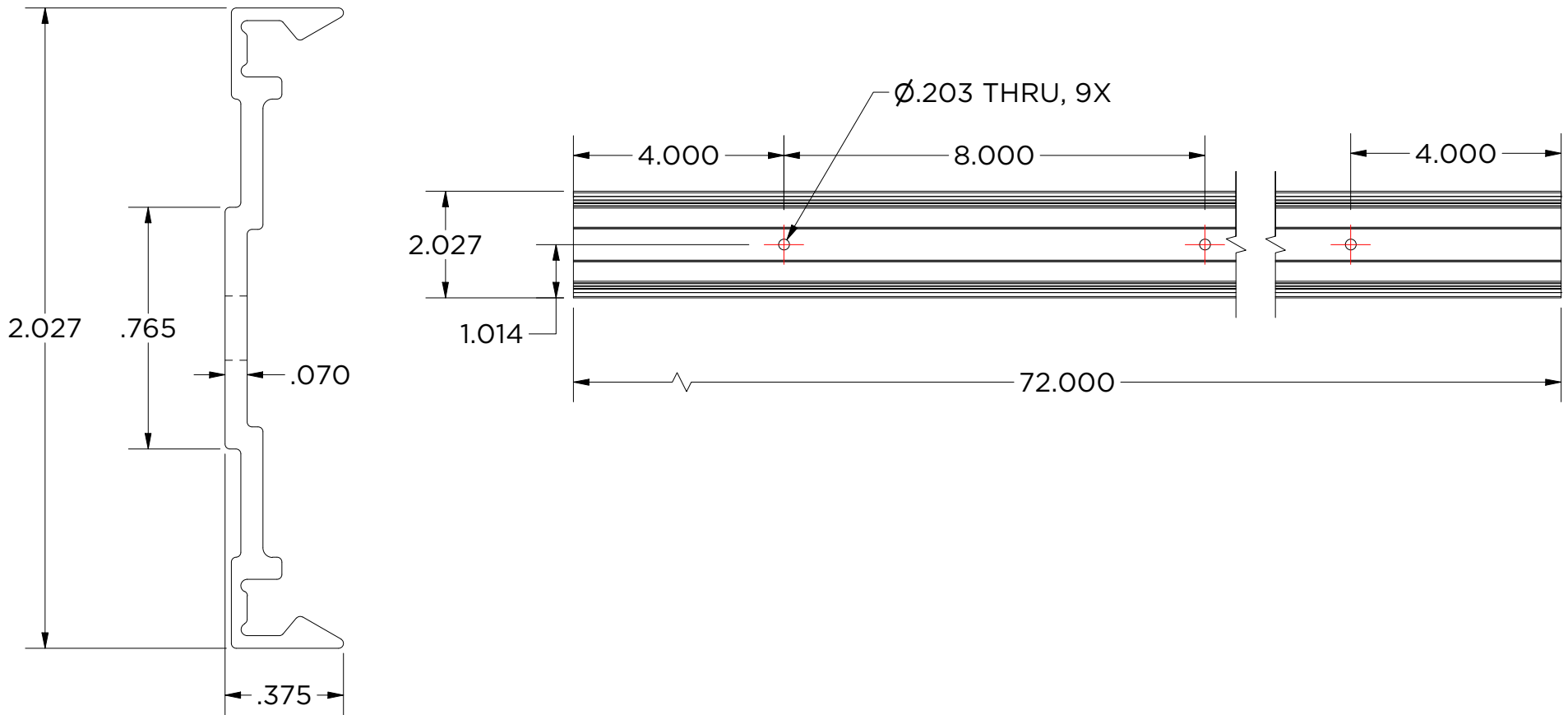

Created By: amh	Approved By:	Sheet Size A	Sheet No. 2/15
Creation Date: 1/7/2025	Approval Date:	Scale 2 : 1	Rev 1

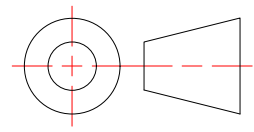

MSNAP-WR72H8

Mates w/MSNAP-PC2, MSNAP-PR72H8,
MSNAP PR144H8
Weight: 1.299 lbmass
Aluminum 6063
Finish: Mill



MONARCH
METAL INC.

PROPRIETARY AND CONFIDENTIAL

THE INFORMATION CONTAINED IN THIS DRAWING IS THE SOLE PROPERTY OF MONARCH METAL FABRICATION. ANY REPRODUCTION IN PART OR AS A WHOLE WITHOUT THE WRITTEN PERMISSION OF MONARCH METAL INC. IS PROHIBITED.

New York
1700 Ocean Ave Suite 2
Ronkonkoma NY 11779
Phone: (631) 750-3000

Nevada
1080 Linda Way, Unit 10
Sparks, NV 89431
Phone: (775) 415-0100

Texas
1330 Post & Paddock St.,
Suite 800
Grand Prairie, TX 75050
(945) 202-2700

monarchmetal.com

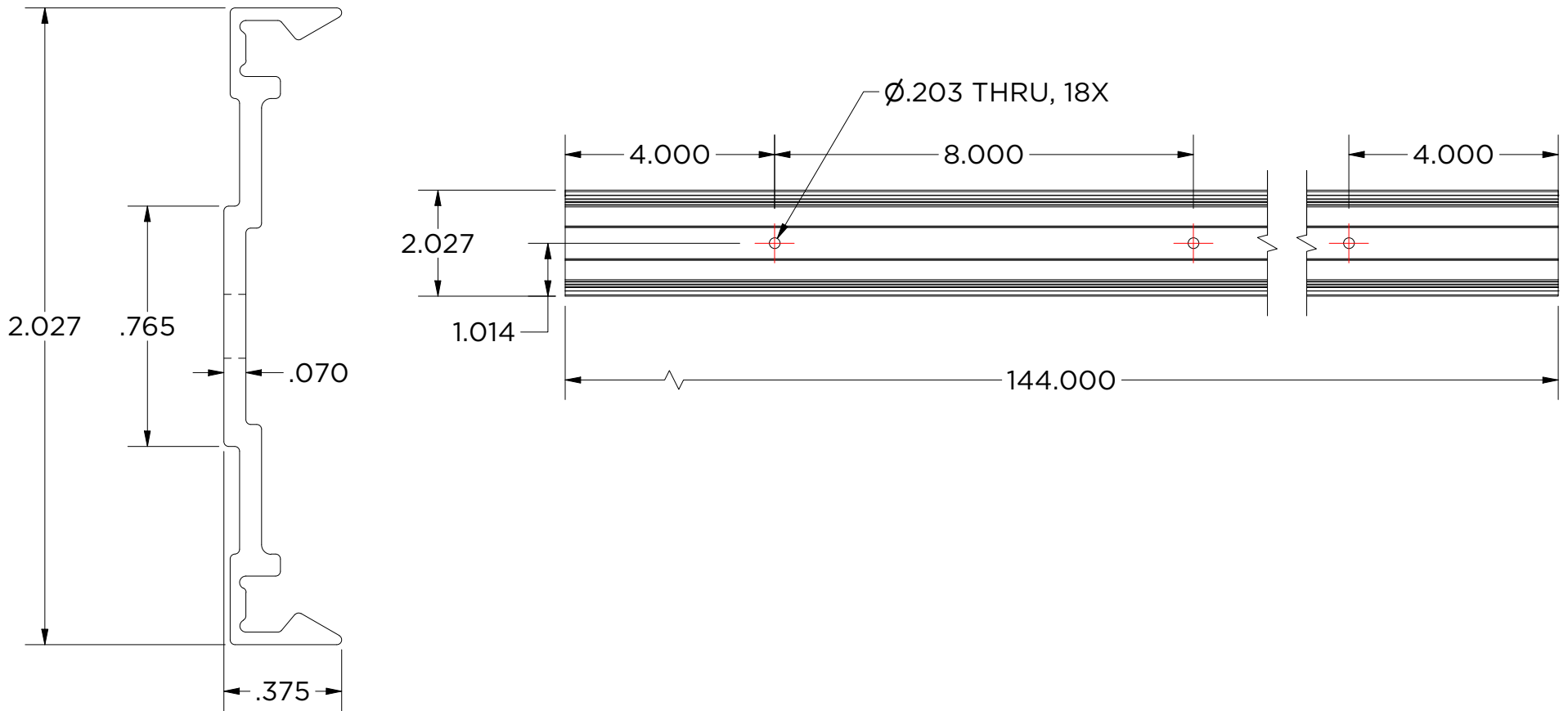

Created By: amh	Approved By:	Sheet Size A	Sheet No. 3/15
Creation Date: 1/7/2025	Approval Date:	Scale 2 : 1	Rev 1

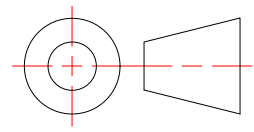

MSNAP-WR144H8

Mates w/MSNAP-PC2, MSNAP-PR72H8,
MSNAP PR144H8
Weight: 2.599 lbmass
Aluminum 6063
Finish: Mill



MONARCH
METAL INC.

PROPRIETARY AND CONFIDENTIAL

THE INFORMATION CONTAINED IN THIS DRAWING IS THE SOLE PROPERTY OF MONARCH METAL FABRICATION. ANY REPRODUCTION IN PART OR AS A WHOLE WITHOUT THE WRITTEN PERMISSION OF MONARCH METAL INC. IS PROHIBITED.

New York
1700 Ocean Ave Suite 2
Ronkonkoma NY 11779
Phone: (631) 750-3000

Nevada
1080 Linda Way, Unit 10
Sparks, NV 89431
Phone: (775) 415-0100

Texas
1330 Post & Paddock St.,
Suite 800
Grand Prairie, TX 75050
(945) 202-2700

monarchmetal.com

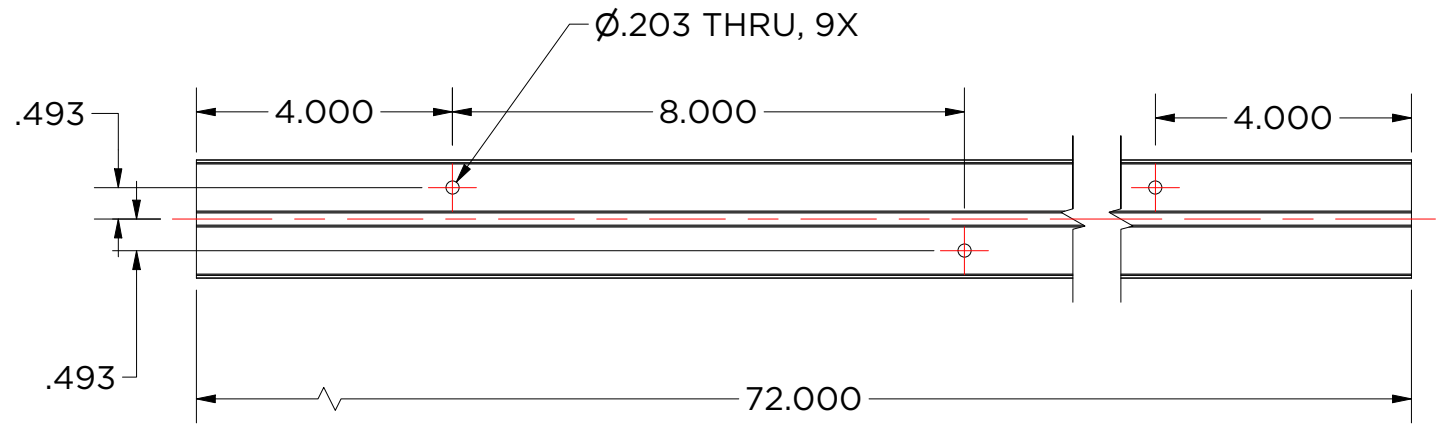
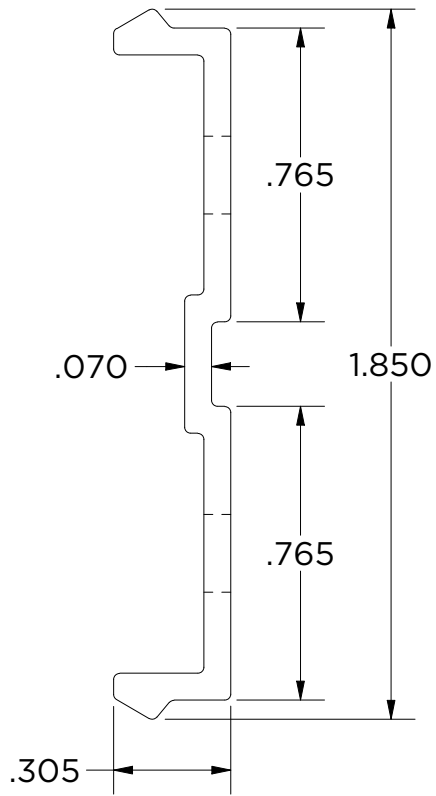

Created By: amh	Approved By:	Sheet Size A	Sheet No. 4/15
Creation Date: 1/7/2025	Approval Date:	Scale 2 : 1	Rev 1

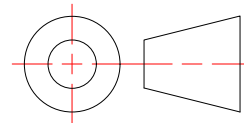

MSNAP-PR72H8

Mates w/MSNAP-WR72H8,
MSNAP-WR144H8
Weight: 1.190 lbmass
Aluminum 6063
Finish: Mill



MONARCH
METAL INC.

PROPRIETARY AND CONFIDENTIAL

THE INFORMATION CONTAINED IN THIS DRAWING IS THE SOLE PROPERTY OF MONARCH METAL FABRICATION. ANY REPRODUCTION IN PART OR AS A WHOLE WITHOUT THE WRITTEN PERMISSION OF MONARCH METAL INC. IS PROHIBITED.

New York
1700 Ocean Ave Suite 2
Ronkonkoma NY 11779
Phone: (631) 750-3000

Nevada
1080 Linda Way, Unit 10
Sparks, NV 89431
Phone: (775) 415-0100

Texas
1330 Post & Paddock St.,
Suite 800
Grand Prairie, TX 75050
(945) 202-2700

monarchmetal.com

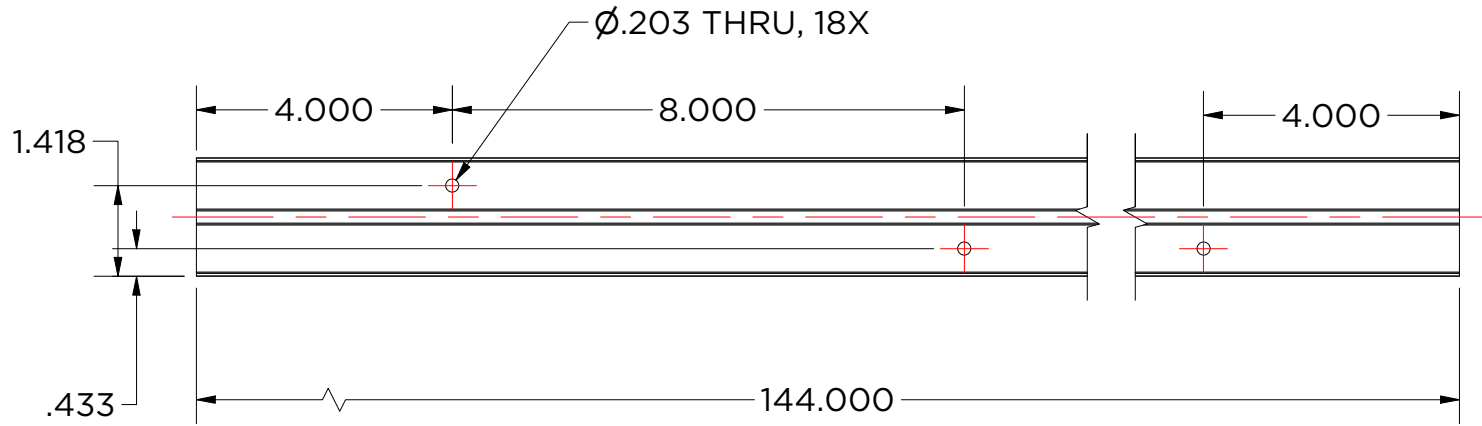
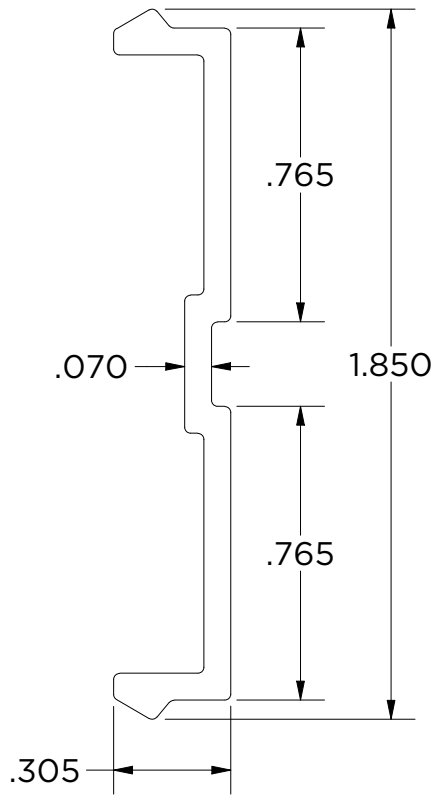

Created By: amh	Approved By:	Sheet Size A	Sheet No. 5/15
Creation Date: 1/7/2025	Approval Date:	Scale 2 : 1	Rev 1

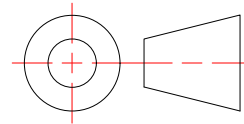

MSNAP-PR144H8

Mates w/MSNAP-WR72H8,
MSNAP-WR144H8
Weight: 2.381 lbmass
Aluminum 6063
Finish: Mill



MONARCH
METAL INC.

PROPRIETARY AND CONFIDENTIAL

THE INFORMATION CONTAINED IN THIS DRAWING IS THE SOLE PROPERTY OF MONARCH METAL FABRICATION. ANY REPRODUCTION IN PART OR AS A WHOLE WITHOUT THE WRITTEN PERMISSION OF MONARCH METAL INC. IS PROHIBITED.

New York
1700 Ocean Ave Suite 2
Ronkonkoma NY 11779
Phone: (631) 750-3000

Nevada
1080 Linda Way, Unit 10
Sparks, NV 89431
Phone: (775) 415-0100

Texas
1330 Post & Paddock St.,
Suite 800
Grand Prairie, TX 75050
(945) 202-2700

monarchmetal.com

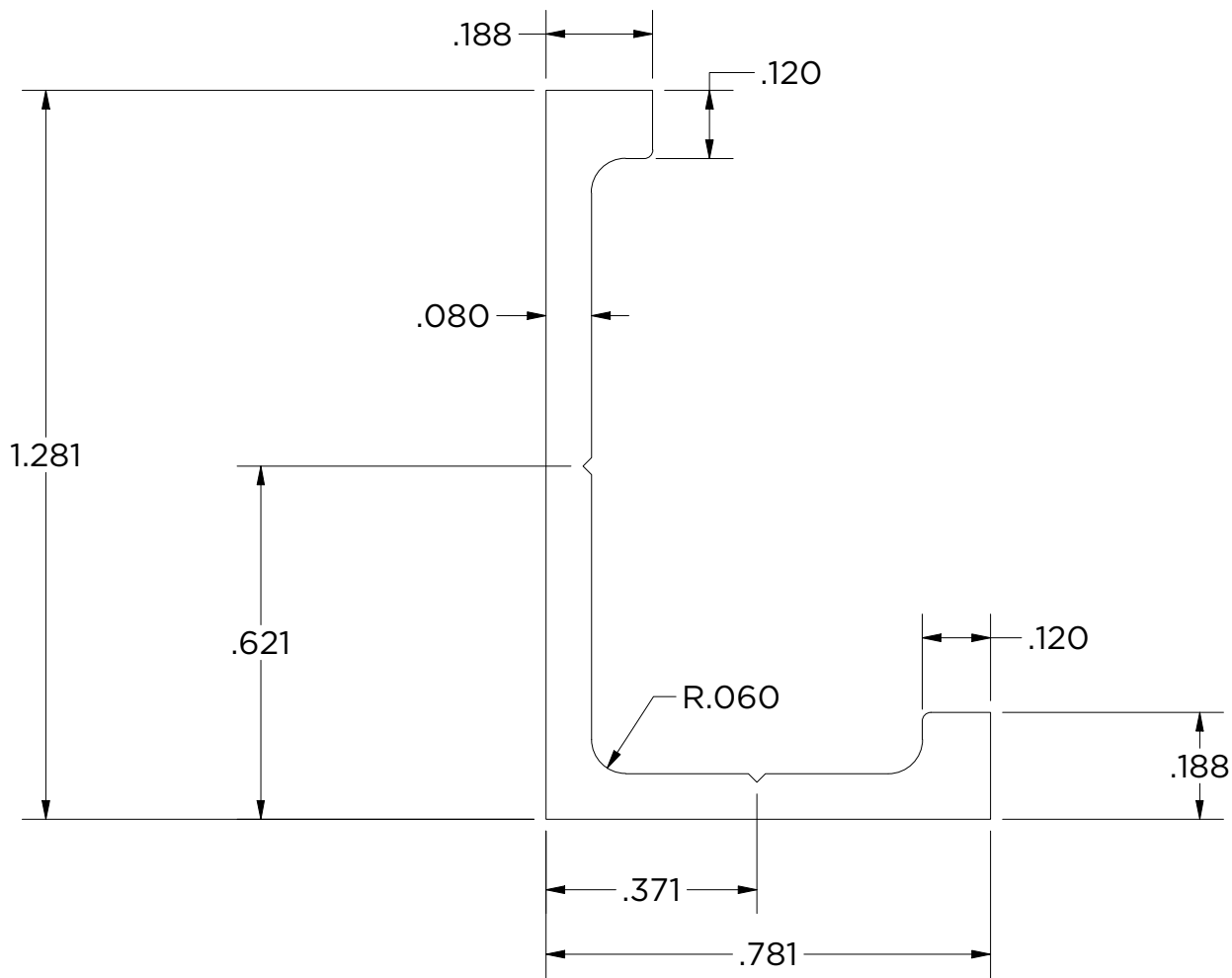

Created By: amh	Approved By:	Sheet Size A	Sheet No. 6/15
Creation Date: 1/7/2025	Approval Date:	Scale 3 : 1	Rev 1

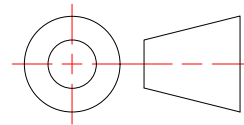

SPS-ET-N
Narrow Edge Trim for SPS

Weight: 2.614 lbmass
Aluminum 6063-T6
Finish: Clear Anodized



MONARCH
METAL INC.

PROPRIETARY AND CONFIDENTIAL

THE INFORMATION CONTAINED IN THIS DRAWING IS THE SOLE PROPERTY OF MONARCH METAL FABRICATION. ANY REPRODUCTION IN PART OR AS A WHOLE WITHOUT THE WRITTEN PERMISSION OF MONARCH METAL INC. IS PROHIBITED.

New York
1700 Ocean Ave Suite 2
Ronkonkoma NY 11779
Phone: (631) 750-3000

Nevada
1080 Linda Way, Unit 10
Sparks, NV 89431
Phone: (775) 415-0100

Texas
1330 Post & Paddock St.,
Suite 800
Grand Prairie, TX 75050
(945) 202-2700

monarchmetal.com

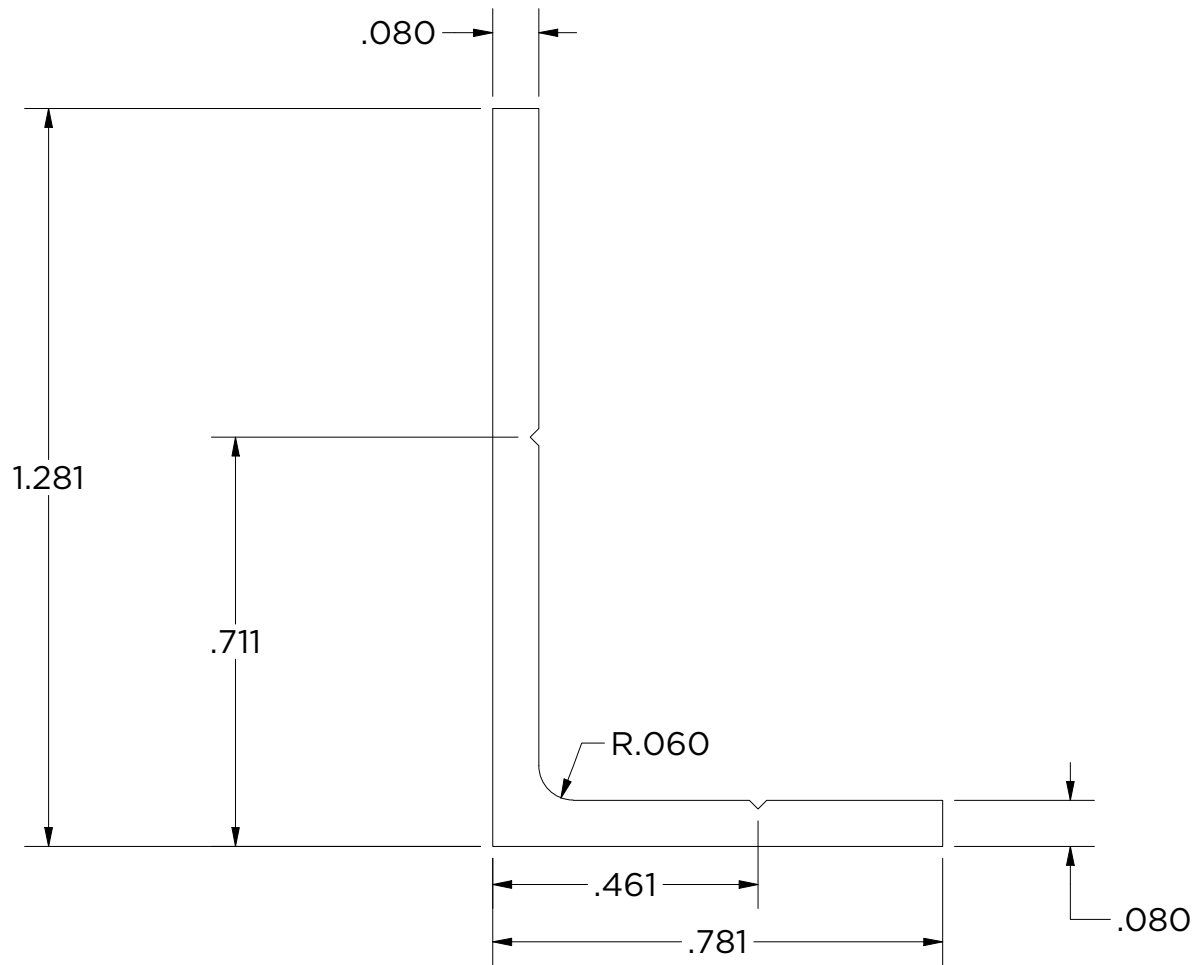

Created By: amh	Approved By:	Sheet Size A	Sheet No. 7/15
Creation Date: 1/7/2025	Approval Date:	Scale 3 : 1	Rev 1

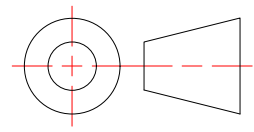

SPS-ET-L
Linear Edge Trim for SPS

Weight: 2.231 lbmass
Aluminum 6063-T6
Finish: Clear Anodized



MONARCH
METAL INC.

PROPRIETARY AND CONFIDENTIAL

THE INFORMATION CONTAINED IN THIS DRAWING IS THE SOLE PROPERTY OF MONARCH METAL FABRICATION. ANY REPRODUCTION IN PART OR AS A WHOLE WITHOUT THE WRITTEN PERMISSION OF MONARCH METAL INC. IS PROHIBITED.

New York
1700 Ocean Ave Suite 2
Ronkonkoma NY 11779
Phone: (631) 750-3000

Nevada
1080 Linda Way, Unit 10
Sparks, NV 89431
Phone: (775) 415-0100

Texas
1330 Post & Paddock St.,
Suite 800
Grand Prairie, TX 75050
(945) 202-2700

monarchmetal.com

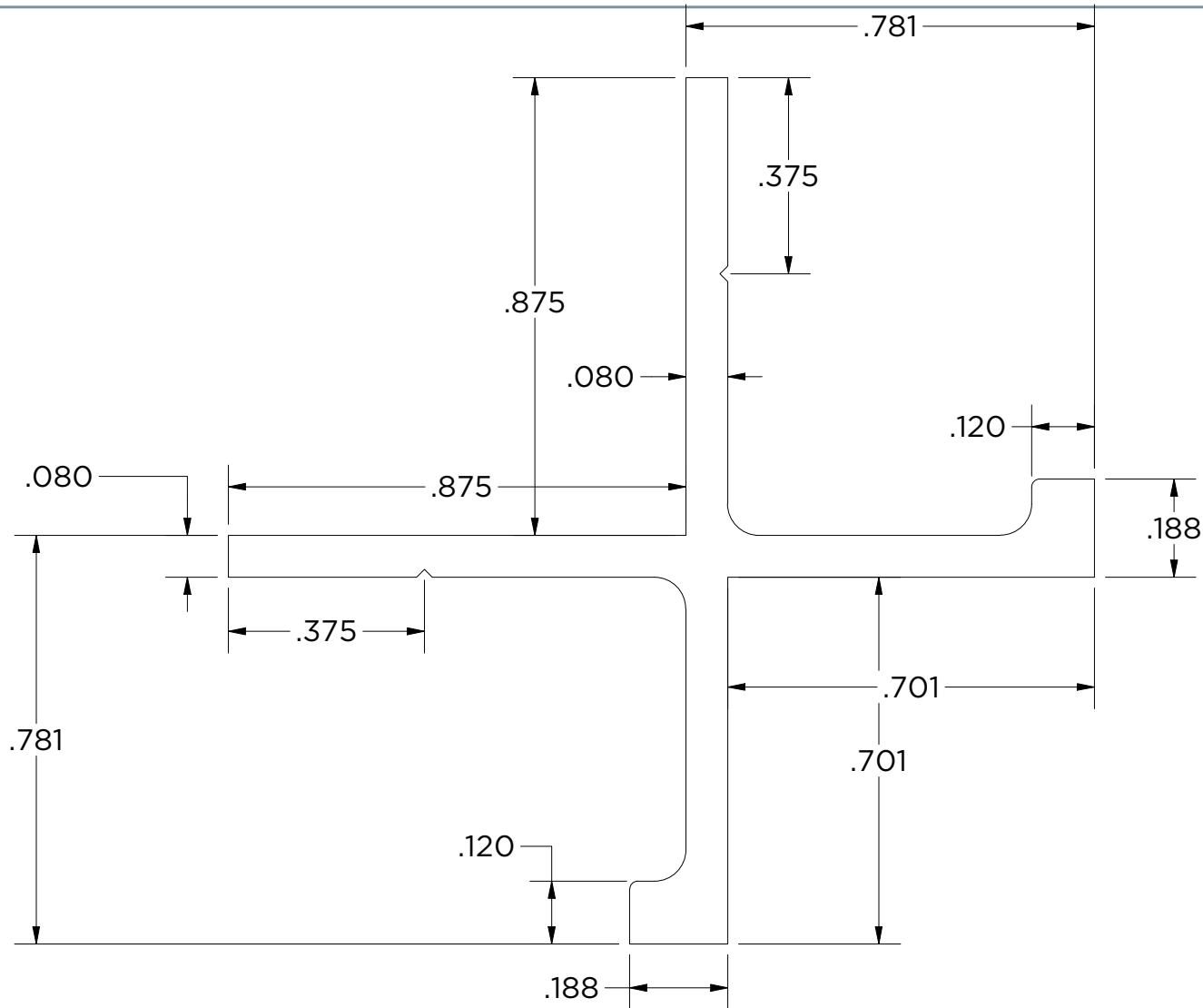

Created By: amh	Approved By:	Sheet Size A	Sheet No. 8/15
Creation Date: 1/7/2025	Approval Date:	Scale 3 : 1	Rev 1

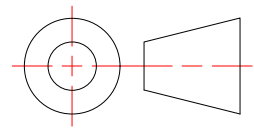

SPS-OC-NSQ

Narrow Square Outside Corner for SPS, 3/8"
(10mm) Panels
Weight: 4.029 lbmass
Aluminum 6063-T6
Finish: Clear Anodized



MONARCH
METAL INC.

PROPRIETARY AND CONFIDENTIAL

THE INFORMATION CONTAINED IN THIS DRAWING IS THE SOLE PROPERTY OF MONARCH METAL FABRICATION. ANY REPRODUCTION IN PART OR AS A WHOLE WITHOUT THE WRITTEN PERMISSION OF MONARCH METAL INC. IS PROHIBITED.

New York 1700 Ocean Ave Suite 2 Ronkonkoma NY 11779 Phone: (631) 750-3000	Nevada 1080 Linda Way, Unit 10 Sparks, NV 89431 Phone: (775) 415-0100	Texas 1330 Post & Paddock St., Suite 800 Grand Prairie, TX 75050 (945) 202-2700
---	---	--

monarchmetal.com

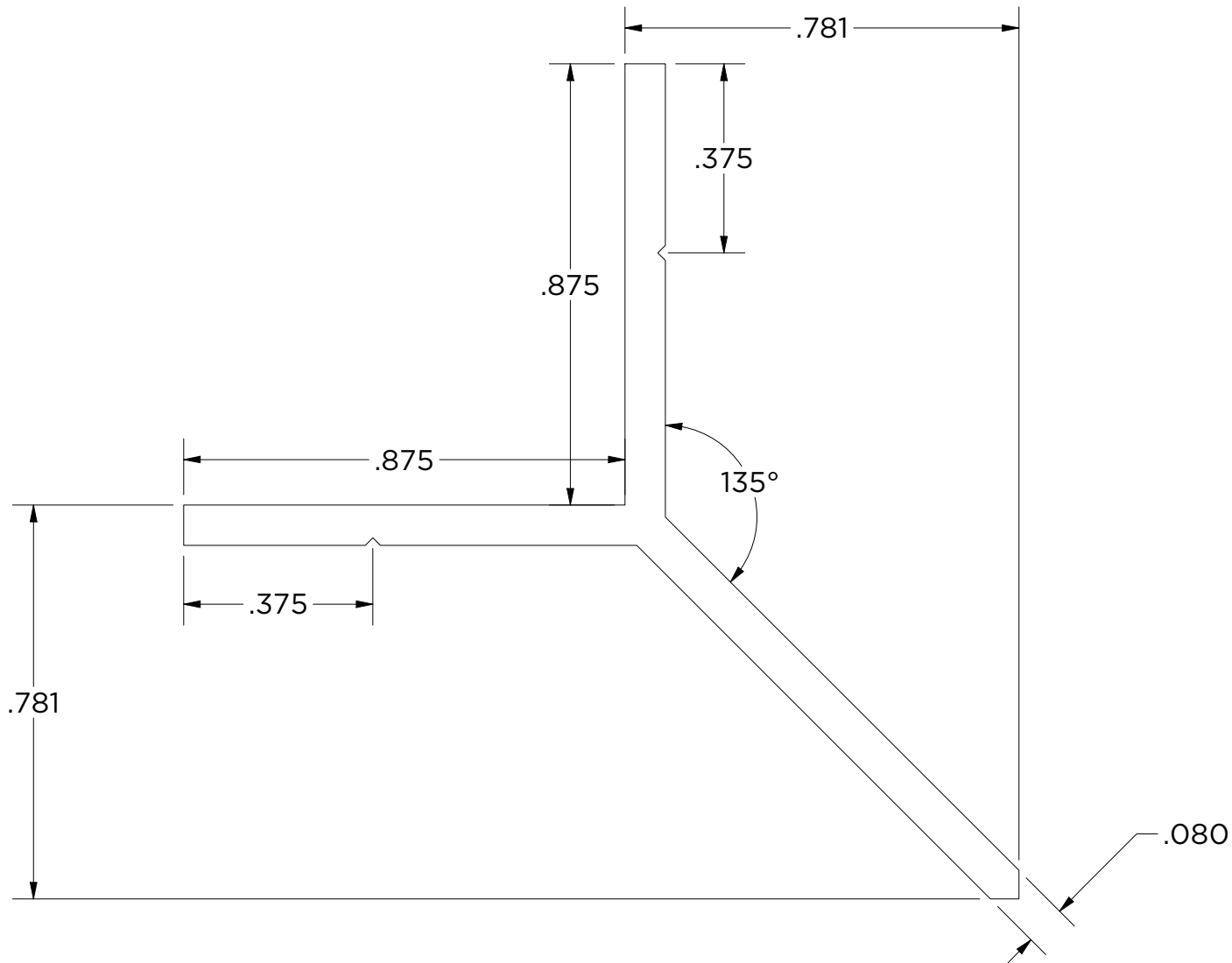

Created By: amh	Approved By:	Sheet Size A	Sheet No. 9/15
Creation Date: 1/7/2025	Approval Date:	Scale 3 : 1	Rev 1

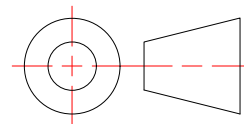

SPS-OC-LM

Linear Miter Outside Corner for SPS,
 3/8"(10mm) Panels
 Weight: 3.163 lbmass
 Aluminum 6063-T6
 Finish: Clear Anodized



MONARCH
 METAL INC.

PROPRIETARY AND CONFIDENTIAL

THE INFORMATION CONTAINED IN THIS DRAWING IS THE SOLE PROPERTY OF MONARCH METAL FABRICATION. ANY REPRODUCTION IN PART OR AS A WHOLE WITHOUT THE WRITTEN PERMISSION OF MONARCH METAL INC. IS PROHIBITED.

New York
 1700 Ocean Ave Suite 2
 Ronkonkoma NY 11779
 Phone: (631) 750-3000

Nevada
 1080 Linda Way, Unit 10
 Sparks, NV 89431
 Phone: (775) 415-0100

Texas
 1330 Post & Paddock St.,
 Suite 800
 Grand Prairie, TX 75050
 (945) 202-2700

monarchmetal.com

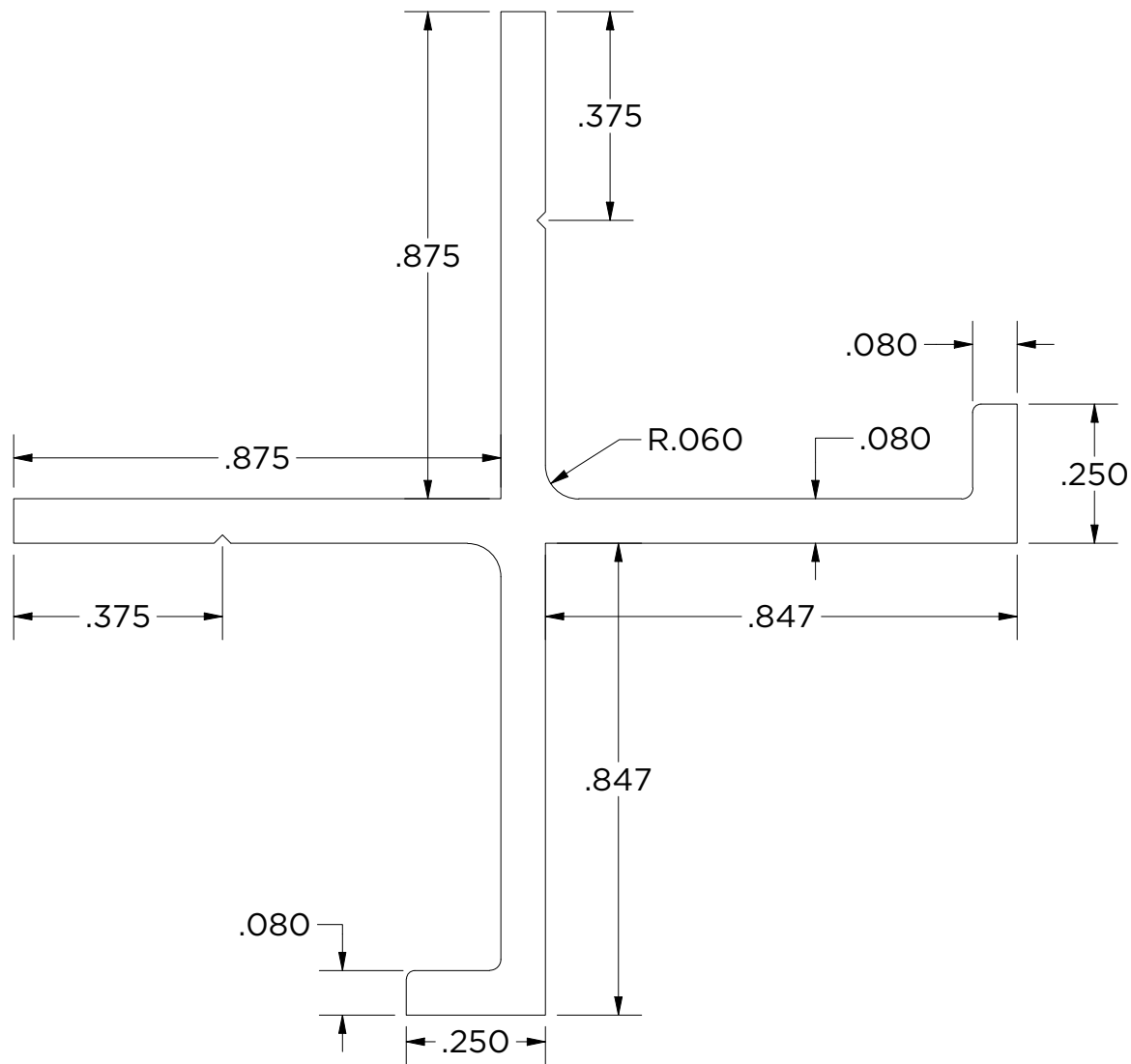

Created By: amh	Approved By:	Sheet Size A	Sheet No. 10/15
Creation Date: 1/7/2025	Approval Date:	Scale 3 : 1	Rev 1

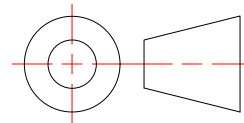

SPS-OC-C

Captured Outside Corner for SPS,
3/8"(10mm) Panels
Weight: 4.359 lbmass
Aluminum 6063
Finish: Clear Anodized



MONARCH
METAL INC.

PROPRIETARY AND CONFIDENTIAL

THE INFORMATION CONTAINED IN THIS DRAWING IS THE SOLE PROPERTY OF MONARCH METAL FABRICATION. ANY REPRODUCTION IN PART OR AS A WHOLE WITHOUT THE WRITTEN PERMISSION OF MONARCH METAL INC. IS PROHIBITED.

New York
1700 Ocean Ave Suite 2
Ronkonkoma NY 11779
Phone: (631) 750-3000

Nevada
1080 Linda Way, Unit 10
Sparks, NV 89431
Phone: (775) 415-0100

Texas
1330 Post & Paddock St.,
Suite 800
Grand Prairie, TX 75050
(945) 202-2700

monarchmetal.com

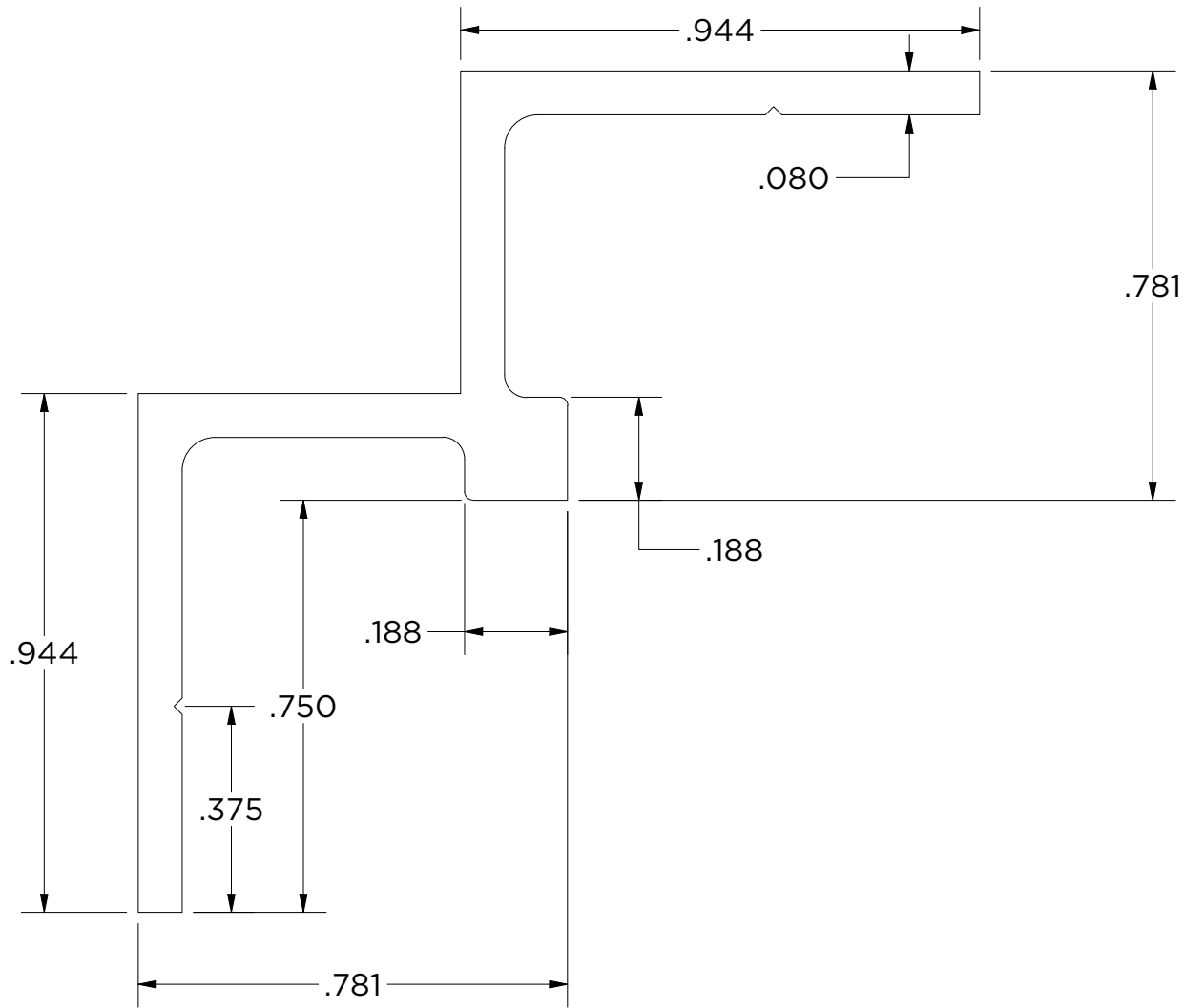

Created By: amh	Approved By:	Sheet Size A	Sheet No. 11/15
Creation Date: 1/7/2025	Approval Date:	Scale 3 : 1	Rev 1

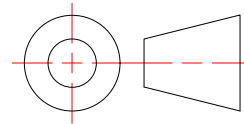

SPS-IC-N

Narrow Inside Corner for SPS, 3/8"(10mm)
Panels
Weight: 3.792 lbmass
Aluminum 6063-T6
Finish: Clear Anodized



MONARCH
METAL INC.

PROPRIETARY AND CONFIDENTIAL

THE INFORMATION CONTAINED IN THIS DRAWING IS THE SOLE PROPERTY OF MONARCH METAL FABRICATION. ANY REPRODUCTION IN PART OR AS A WHOLE WITHOUT THE WRITTEN PERMISSION OF MONARCH METAL INC. IS PROHIBITED.

New York
1700 Ocean Ave Suite 2
Ronkonkoma NY 11779
Phone: (631) 750-3000

Nevada
1080 Linda Way, Unit 10
Sparks, NV 89431
Phone: (775) 415-0100

Texas
1330 Post & Paddock St.,
Suite 800
Grand Prairie, TX 75050
(945) 202-2700

monarchmetal.com

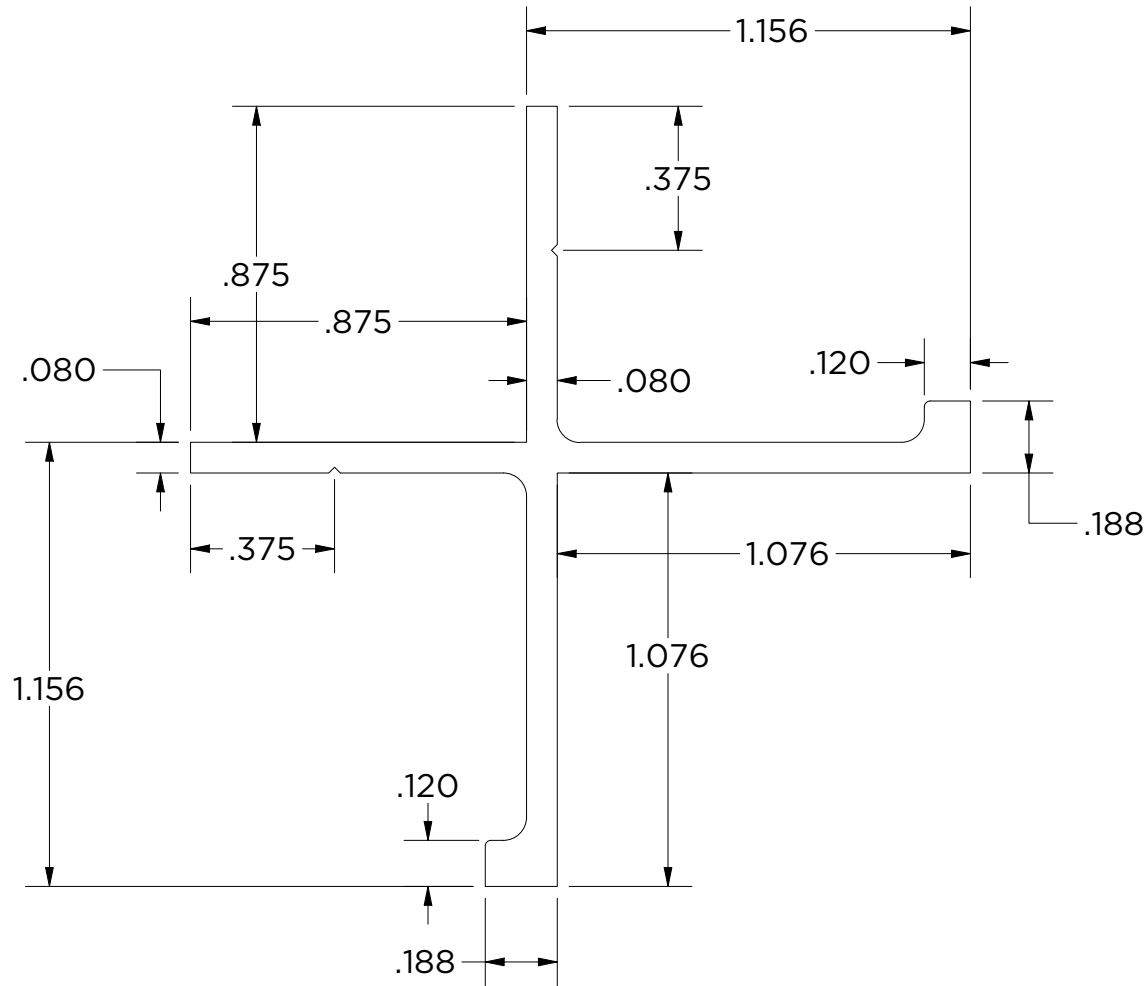

Created By: amh	Approved By:	Sheet Size A	Sheet No. 12/15
Creation Date: 1/7/2025	Approval Date:	Scale 2 : 1	Rev 1

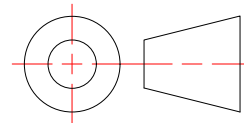

SPS-OC-NSQ-75

Narrow Square Outside Corner for SPS,
3/4"(19mm) Panels
Weight: 4.871 lbmass
Aluminum 6063-T6
Finish: Clear Anodized



MONARCH
METAL INC.

PROPRIETARY AND CONFIDENTIAL

THE INFORMATION CONTAINED IN THIS DRAWING IS THE SOLE PROPERTY OF MONARCH METAL FABRICATION. ANY REPRODUCTION IN PART OR AS A WHOLE WITHOUT THE WRITTEN PERMISSION OF MONARCH METAL INC. IS PROHIBITED.

New York
1700 Ocean Ave Suite 2
Ronkonkoma NY 11779
Phone: (631) 750-3000

Nevada
1080 Linda Way, Unit 10
Sparks, NV 89431
Phone: (775) 415-0100

Texas
1330 Post & Paddock St.,
Suite 800
Grand Prairie, TX 75050
(945) 202-2700

monarchmetal.com

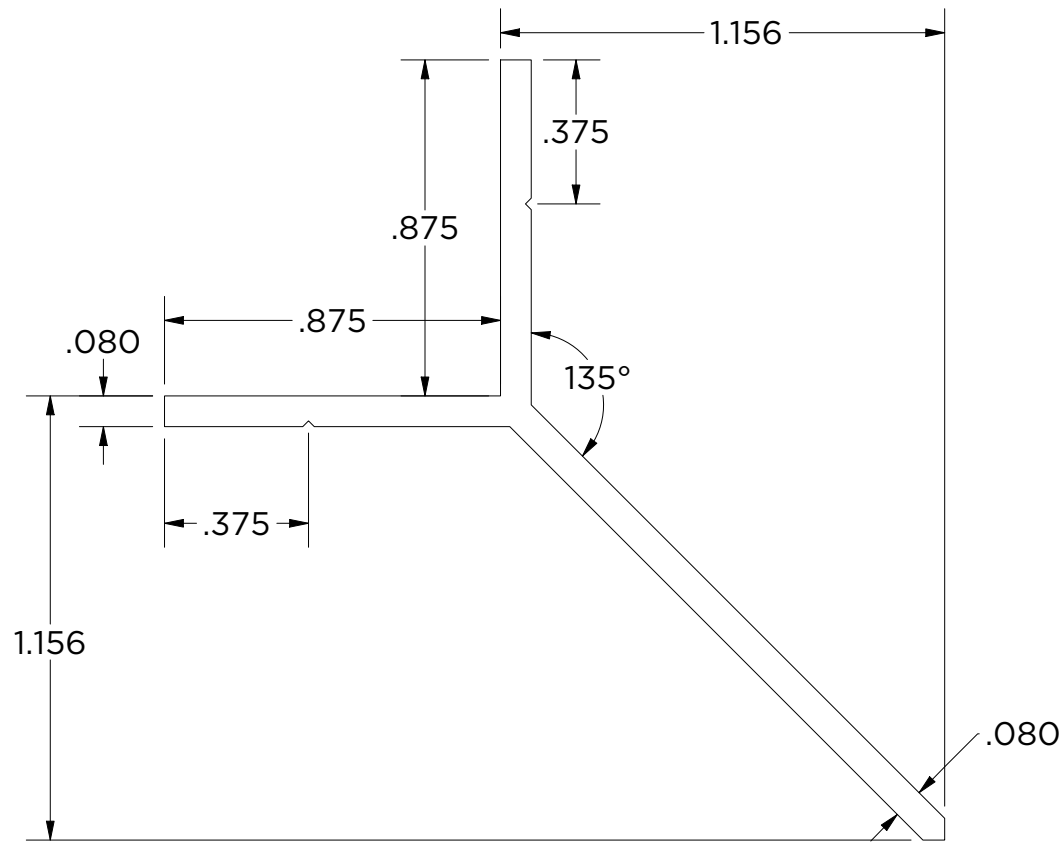

Created By: amh	Approved By:	Sheet Size A	Sheet No. 13/15
Creation Date: 1/7/2025	Approval Date:	Scale 2 : 1	Rev 1

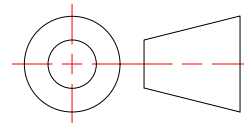

SPS-OC-LM-75

Linear Miter Outside Corner for SPS,
3/4"(19mm) Panels
Weight: 3.759 lbmass
Aluminum 6063-T6
Finish: Clear Anodized



MONARCH
METAL INC.

PROPRIETARY AND CONFIDENTIAL

THE INFORMATION CONTAINED IN THIS DRAWING IS THE SOLE PROPERTY OF MONARCH METAL FABRICATION. ANY REPRODUCTION IN PART OR AS A WHOLE WITHOUT THE WRITTEN PERMISSION OF MONARCH METAL INC. IS PROHIBITED.

New York
1700 Ocean Ave Suite 2
Ronkonkoma NY 11779
Phone: (631) 750-3000

Nevada
1080 Linda Way, Unit 10
Sparks, NV 89431
Phone: (775) 415-0100

Texas
1330 Post & Paddock St.,
Suite 800
Grand Prairie, TX 75050
(945) 202-2700

monarchmetal.com

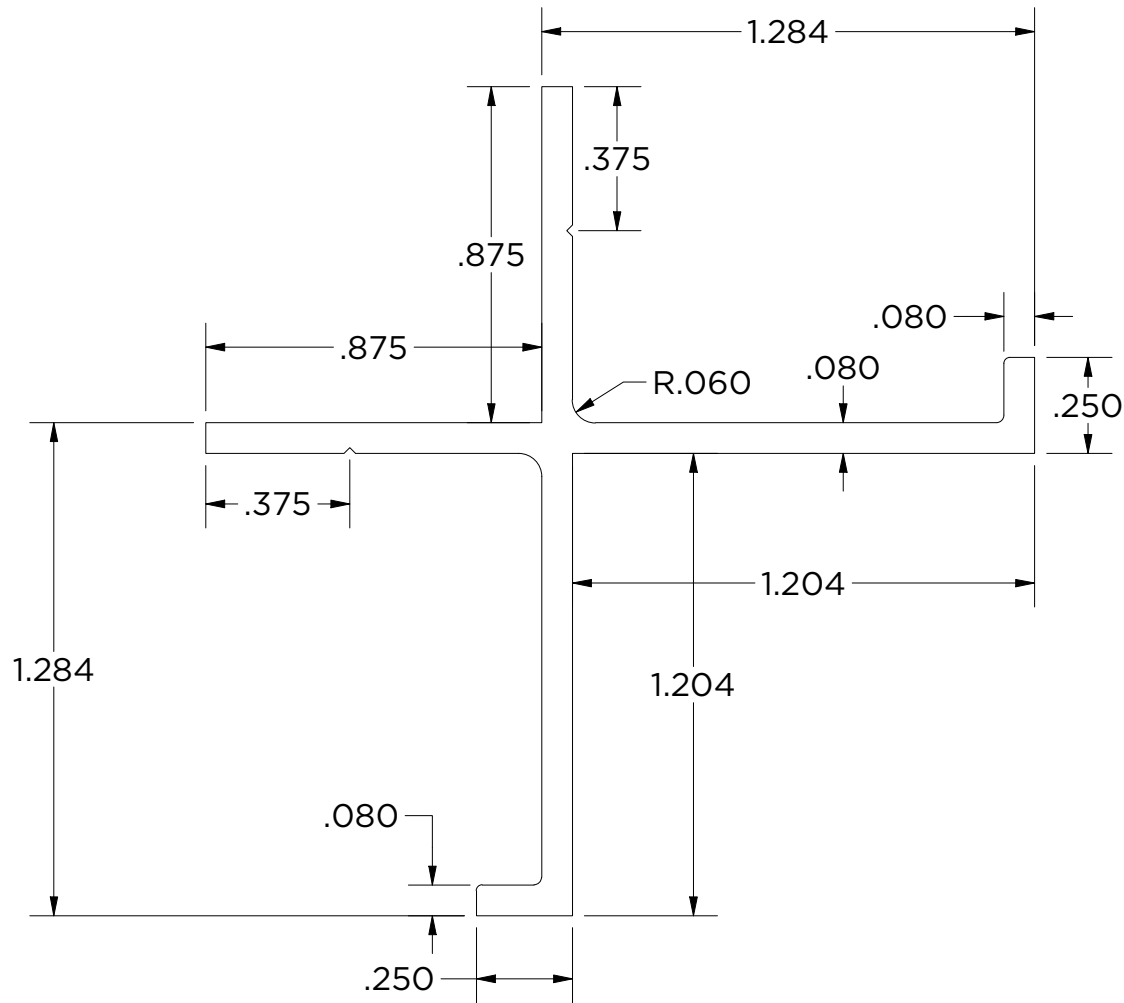

Created By: amh	Approved By:	Sheet Size A	Sheet No. 14/15
Creation Date: 1/7/2025	Approval Date:	Scale 2 : 1	Rev 1

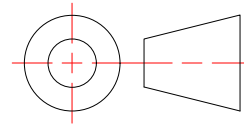

SPS-OC-C-75

Captured Outside Corner for SPS,
3/4"(19mm) Panels
Weight: 5.160 lbmass
Aluminum 6063
Finish: Clear Anodized



MONARCH
METAL INC.

PROPRIETARY AND CONFIDENTIAL

THE INFORMATION CONTAINED IN THIS DRAWING IS THE SOLE PROPERTY OF MONARCH METAL FABRICATION. ANY REPRODUCTION IN PART OR AS A WHOLE WITHOUT THE WRITTEN PERMISSION OF MONARCH METAL INC. IS PROHIBITED.

New York
1700 Ocean Ave Suite 2
Ronkonkoma NY 11779
Phone: (631) 750-3000

Nevada
1080 Linda Way, Unit 10
Sparks, NV 89431
Phone: (775) 415-0100

Texas
1330 Post & Paddock St.,
Suite 800
Grand Prairie, TX 75050
(945) 202-2700

monarchmetal.com

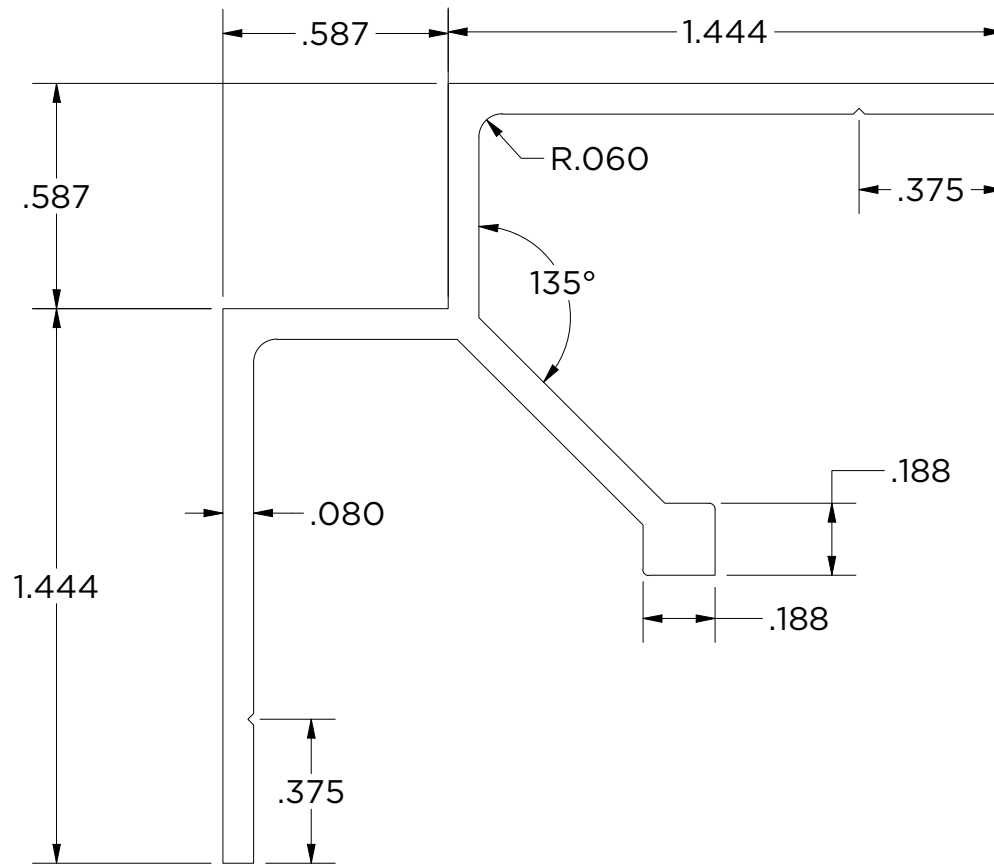

Created By: amh	Approved By:	Sheet Size A	Sheet No. 15/15
Creation Date: 1/7/2025	Approval Date:	Scale 2 : 1	Rev 1

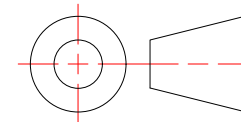

SPS-IC-N-75

Narrow Inside Corner for SPS, 3/4"(19mm)
Panels
Weight: 5.704 lbmass
Aluminum 6063-T6
Finish: Clear Anodized



MONARCH
METAL INC.

PROPRIETARY AND CONFIDENTIAL

THE INFORMATION CONTAINED IN THIS DRAWING IS THE SOLE PROPERTY OF MONARCH METAL FABRICATION. ANY REPRODUCTION IN PART OR AS A WHOLE WITHOUT THE WRITTEN PERMISSION OF MONARCH METAL INC. IS PROHIBITED.

New York
1700 Ocean Ave Suite 2
Ronkonkoma NY 11779
Phone: (631) 750-3000

Nevada
1080 Linda Way, Unit 10
Sparks, NV 89431
Phone: (775) 415-0100

Texas
1330 Post & Paddock St.,
Suite 800
Grand Prairie, TX 75050
(945) 202-2700

monarchmetal.com