

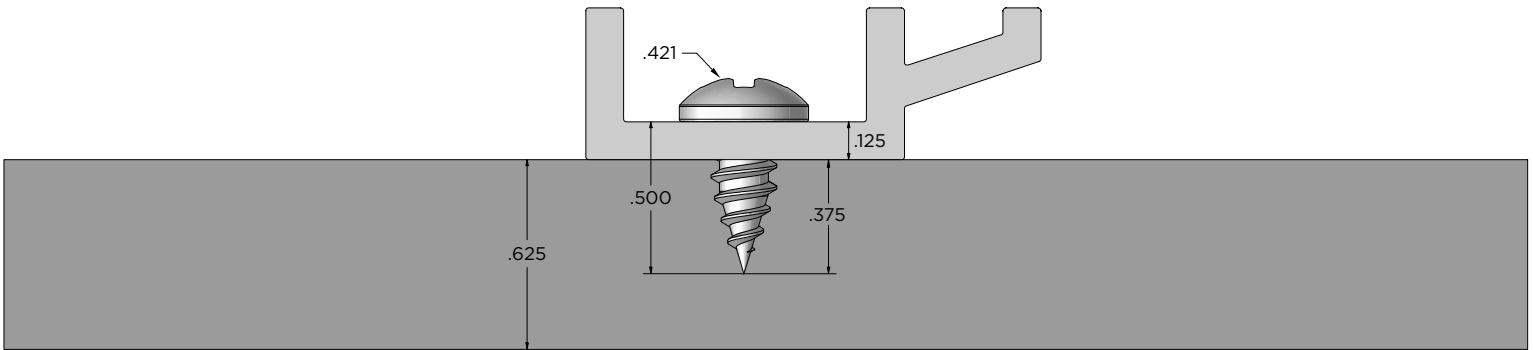

## PANEL THICKNESS RECOMMENDATION

Use the reference table below to identify the optimal fastener length based on specified panel thickness and MFSTR product.

Monarch Product	Flange Thickness	Screw Size	Panel Min.	Panel Max.
MFSTR-0375	0.125"	#12x1/2	0.625"	0.875"
		#12x3/4	1.00"	1.50"
MFSTR-050	0.125"	#12x1/2	0.625"	0.875"
		#12x3/4	1.00"	1.50"
MFSTR-075	0.1875"	#12x1/2	0.50"	0.75"
		#12x3/4	0.875"	1.375"



## SCREW EMBEDMENT DEPTH

Screw embedment depth refers to the total distance the threaded portion of a fastener penetrates the panel material. To ensure a secure, high-withdrawal-resistance connection, the typical range of depth is between 40-70%.

Panel Thickness	MFSTR-0375		MFSTR-050		MFSTR-075							
	#12x1/2	#12x3/4	#12x1/2	#12x3/4	#12x1/2	#12x3/4						
0.625"	0.375"	60%	0.625"	-	0.375"	60%	0.625"	-	0.3125"	50%	0.5625"	-
0.75"	0.375"	50%	0.625"	-	0.375"	50%	0.625"	-	0.3125"	41.7%	0.5625"	75%
0.875"	0.375"	42.9%	0.625"	71.4%	0.375"	42.9%	0.625"	71.4%	0.3125"	35.7%	0.5625"	64.3%
1.00"	0.375"	37.5%	0.625"	62.5%	0.375"	37.5%	0.625"	62.5%	0.3125"	31.3%	0.5625"	56.3%
1.25"	0.375"	30%	0.625"	50%	0.375"	30%	0.625"	50%	0.3125"	25%	0.5625"	45%
1.375"	0.375"	27.3%	0.625"	45.5%	0.375"	27.3%	0.625"	45.5%	0.3125"	22.7%	0.5625"	40.9%
1.50"	0.375"	25%	0.625"	41.7%	0.375"	25%	0.625"	41.7%	0.3125"	20.8%	0.5625"	37.5%

Typical Range is 40-70%

