

Created By: amh	Approved By:	Sheet Size A	Sheet No. 1/9
Creation Date: 7/25/2024	Approval Date:	Scale 1:1	Rev 2

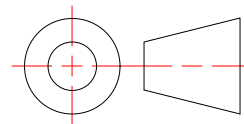

MCG-3-24-CB

Weight: 2.556 lbmass
Stainless Steel
Finish: #4 Brushed



MONARCH
METAL INC.

PROPRIETARY AND CONFIDENTIAL

THE INFORMATION CONTAINED IN THIS DRAWING IS THE SOLE PROPERTY OF MONARCH METAL FABRICATION. ANY REPRODUCTION IN PART OR AS A WHOLE WITHOUT THE WRITTEN PERMISSION OF MONARCH METAL INC. IS PROHIBITED.

New York
1700 Ocean Ave Suite 2
Ronkonkoma NY 11779
Phone: (631) 750-3000

Nevada
1080 Linda Way, Unit 10
Sparks, NV 89431
Phone: (775) 415-0100

Texas
1330 Post & Paddock St.,
Suite 800
Grand Prairie, TX 75050
(945) 202-2700

monarchmetal.com

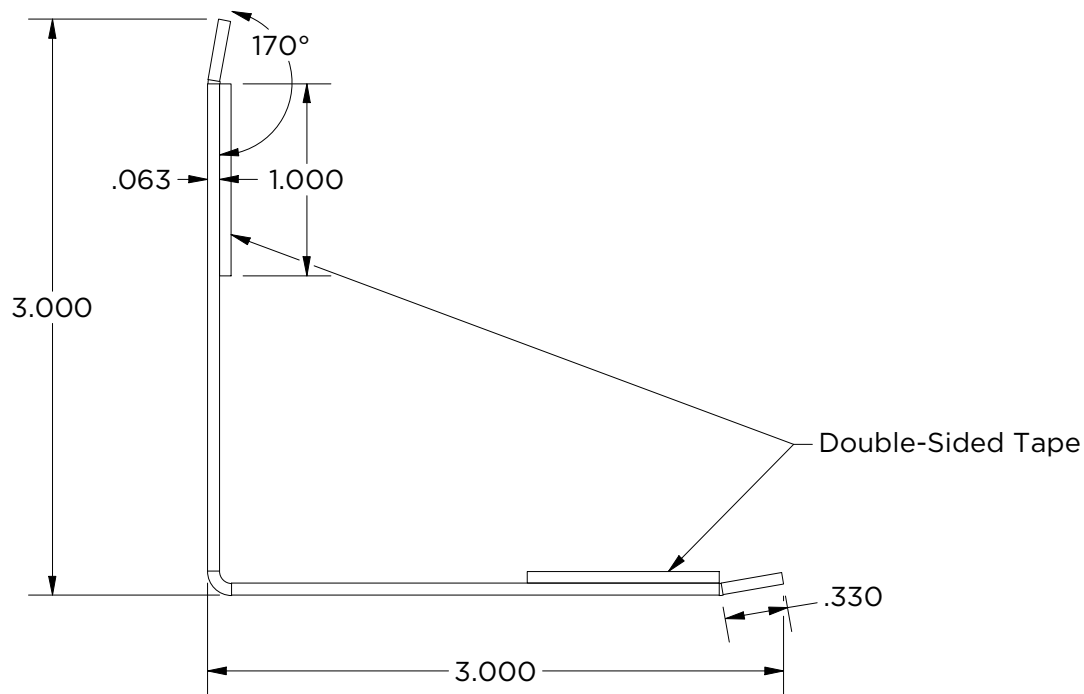

Created By: amh	Approved By:	Sheet Size A	Sheet No. 2/9
Creation Date: 7/25/2024	Approval Date:	Scale 1 / 7	Rev 2

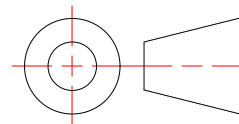

MCG-3-24T-CB

Weight: 2.556 lbmass
Stainless Steel
Finish: #4 Brushed



MONARCH
METAL INC.

PROPRIETARY AND CONFIDENTIAL

THE INFORMATION CONTAINED IN THIS DRAWING IS THE SOLE PROPERTY OF MONARCH METAL FABRICATION. ANY REPRODUCTION IN PART OR AS A WHOLE WITHOUT THE WRITTEN PERMISSION OF MONARCH METAL INC. IS PROHIBITED.

New York
1700 Ocean Ave Suite 2
Ronkonkoma NY 11779
Phone: (631) 750-3000

Nevada
1080 Linda Way, Unit 10
Sparks, NV 89431
Phone: (775) 415-0100

Texas
1330 Post & Paddock St.,
Suite 800
Grand Prairie, TX 75050
(945) 202-2700

monarchmetal.com

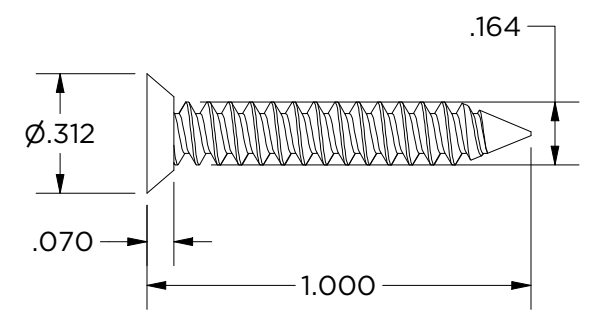
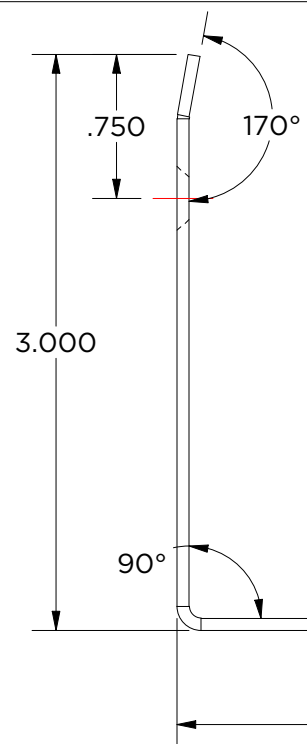
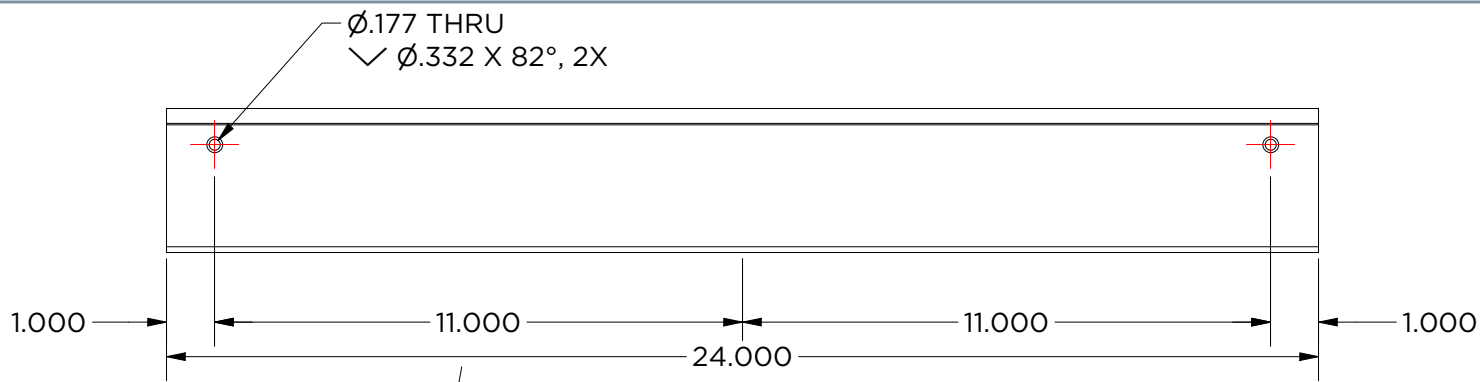

18-8 Stainless Undercut #8x1 Screw
QTY (4)

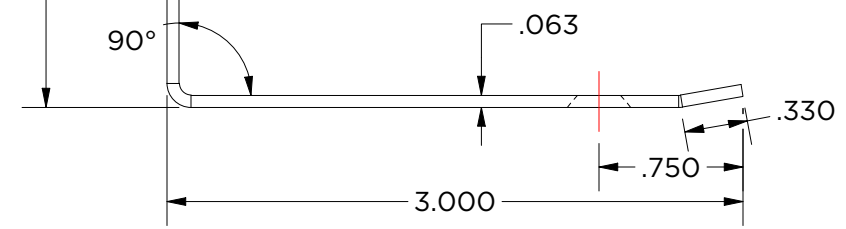

Created By: amh	Approved By:	Sheet Size A	Sheet No. 3/9
Creation Date: 7/25/2024	Approval Date:	Scale 1:1	Rev 2

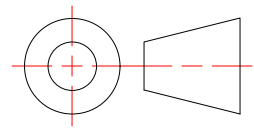

MCG-3-24H-CB

Weight: 2.552 lbmass
Stainless Steel
Finish: #4 Brushed



MONARCH
METAL INC.

PROPRIETARY AND CONFIDENTIAL
THE INFORMATION CONTAINED IN THIS DRAWING IS THE SOLE PROPERTY OF MONARCH METAL FABRICATION. ANY REPRODUCTION IN PART OR AS A WHOLE WITHOUT THE WRITTEN PERMISSION OF MONARCH METAL INC. IS PROHIBITED.

New York 1700 Ocean Ave Suite 2 Ronkonkoma NY 11779 Phone: (631) 750-3000	Nevada 1080 Linda Way, Unit 10 Sparks, NV 89431 Phone: (775) 415-0100	Texas 1330 Post & Paddock St., Suite 800 Grand Prairie, TX 75050 (945) 202-2700
---	---	--

monarchmetal.com

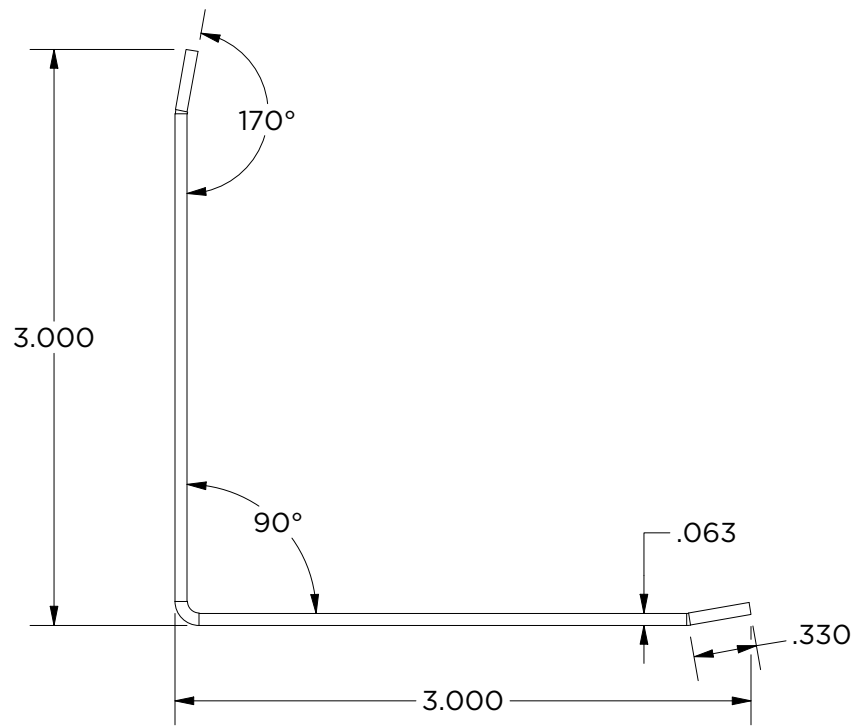

Created By: amh	Approved By:	Sheet Size A	Sheet No. 4/9
Creation Date: 7/25/2024	Approval Date:	Scale 1:1	Rev 2

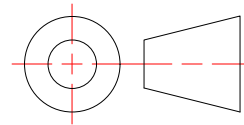

MCG-3-48-CB

Weight: 5.112 lbmass
Stainless Steel
Finish: #4 Brushed



MONARCH
METAL INC.

PROPRIETARY AND CONFIDENTIAL

THE INFORMATION CONTAINED IN THIS DRAWING IS THE SOLE PROPERTY OF MONARCH METAL FABRICATION. ANY REPRODUCTION IN PART OR AS A WHOLE WITHOUT THE WRITTEN PERMISSION OF MONARCH METAL INC. IS PROHIBITED.

New York
1700 Ocean Ave Suite 2
Ronkonkoma NY 11779
Phone: (631) 750-3000

Nevada
1080 Linda Way, Unit 10
Sparks, NV 89431
Phone: (775) 415-0100

Texas
1330 Post & Paddock St.,
Suite 800
Grand Prairie, TX 75050
(945) 202-2700

monarchmetal.com

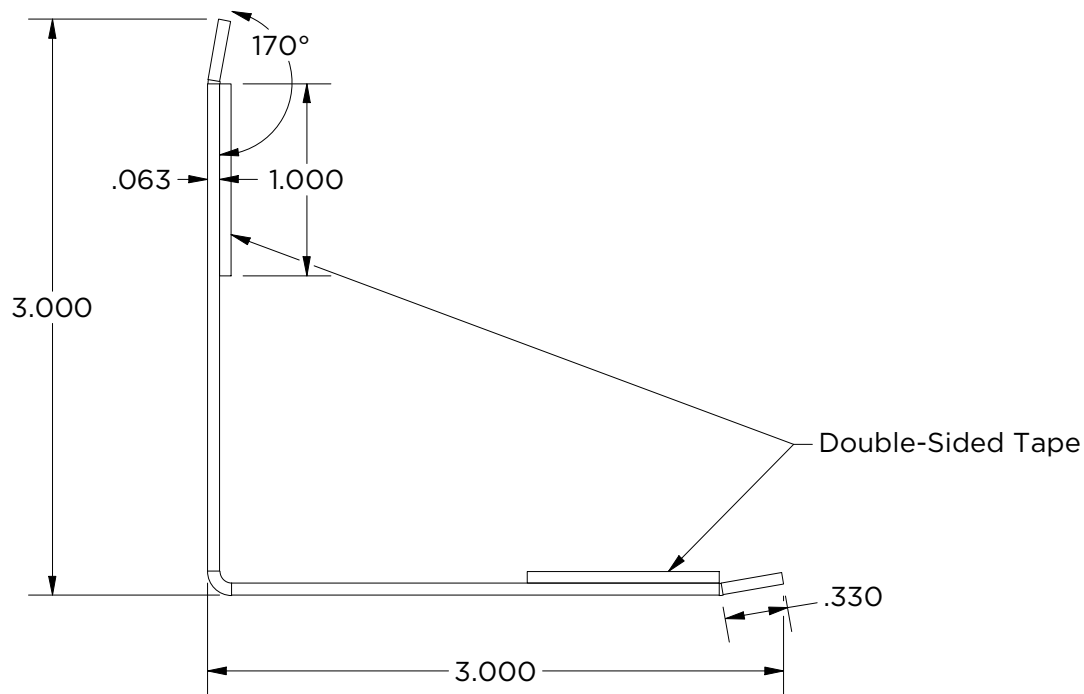

Created By: amh	Approved By:	Sheet Size A	Sheet No. 5/9
Creation Date: 7/25/2024	Approval Date:	Scale 1/14	Rev 2

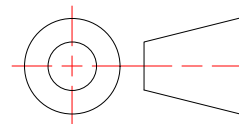

MCG-3-48T-CB

Weight: 5.112 lbmass
Stainless Steel
Finish: #4 Brushed



MONARCH
METAL INC.

PROPRIETARY AND CONFIDENTIAL

THE INFORMATION CONTAINED IN THIS DRAWING IS THE SOLE PROPERTY OF MONARCH METAL FABRICATION. ANY REPRODUCTION IN PART OR AS A WHOLE WITHOUT THE WRITTEN PERMISSION OF MONARCH METAL INC. IS PROHIBITED.

New York
1700 Ocean Ave Suite 2
Ronkonkoma NY 11779
Phone: (631) 750-3000

Nevada
1080 Linda Way, Unit 10
Sparks, NV 89431
Phone: (775) 415-0100

Texas
1330 Post & Paddock St.,
Suite 800
Grand Prairie, TX 75050
(945) 202-2700

monarchmetal.com

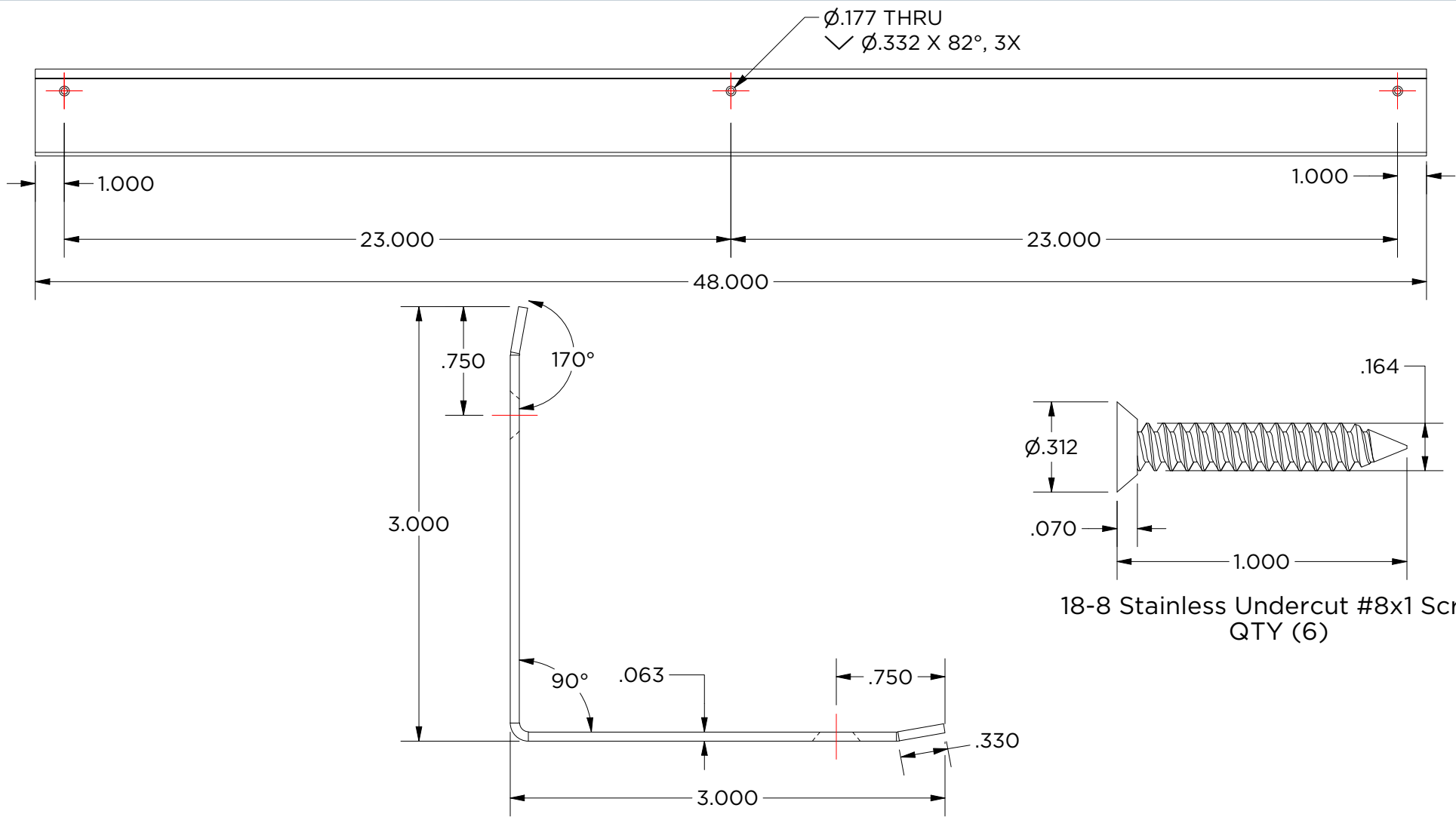

Created By: amh	Approved By:	Sheet Size A	Sheet No. 6/9
Creation Date: 7/25/2024	Approval Date:	Scale 1:1	Rev 2

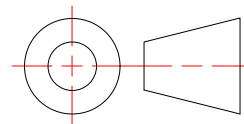

MCG-3-48H-CB

Weight: 5.106 lbmass
Stainless Steel
Finish: #4 Brushed



MONARCH
METAL INC.

PROPRIETARY AND CONFIDENTIAL

THE INFORMATION CONTAINED IN THIS DRAWING IS THE SOLE PROPERTY OF MONARCH METAL FABRICATION. ANY REPRODUCTION IN PART OR AS A WHOLE WITHOUT THE WRITTEN PERMISSION OF MONARCH METAL INC. IS PROHIBITED.

New York
1700 Ocean Ave Suite 2
Ronkonkoma NY 11779
Phone: (631) 750-3000

Nevada
1080 Linda Way, Unit 10
Sparks, NV 89431
Phone: (775) 415-0100

Texas
1330 Post & Paddock St.,
Suite 800
Grand Prairie, TX 75050
(945) 202-2700

monarchmetal.com

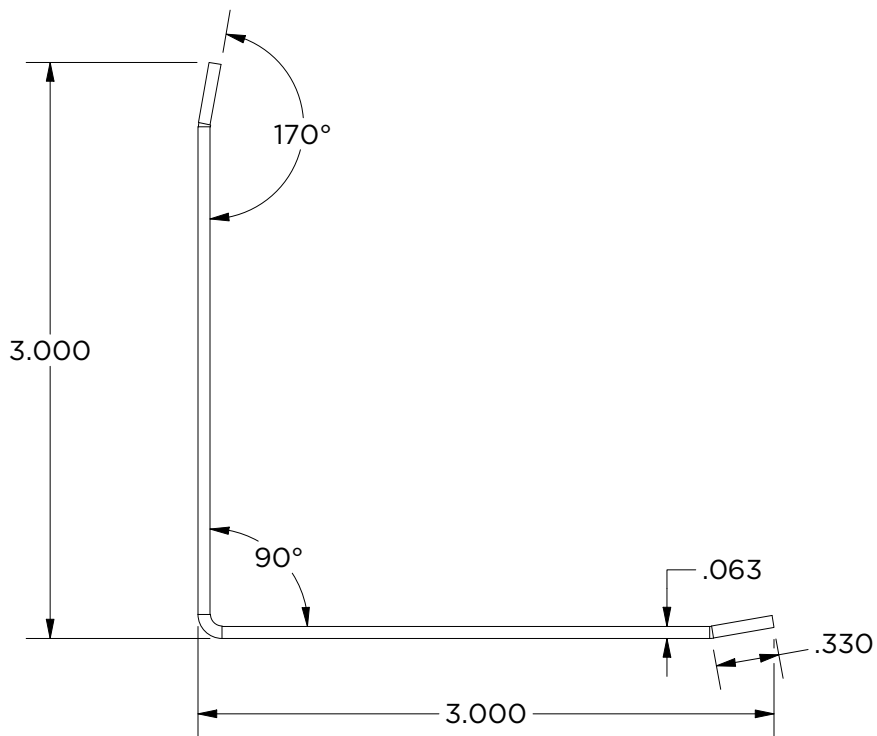

Created By: amh	Approved By:	Sheet Size A	Sheet No. 7/9
Creation Date: 7/25/2024	Approval Date:	Scale 1:1	Rev 2

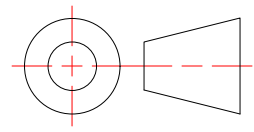

MCG-3-92-CB

Weight: 9.799 lbmass
Stainless Steel
Finish: #4 Brushed



MONARCH
METAL INC.

PROPRIETARY AND CONFIDENTIAL

THE INFORMATION CONTAINED IN THIS DRAWING IS THE SOLE PROPERTY OF MONARCH METAL FABRICATION. ANY REPRODUCTION IN PART OR AS A WHOLE WITHOUT THE WRITTEN PERMISSION OF MONARCH METAL INC. IS PROHIBITED.

New York 1700 Ocean Ave Suite 2 Ronkonkoma NY 11779 Phone: (631) 750-3000	Nevada 1080 Linda Way, Unit 10 Sparks, NV 89431 Phone: (775) 415-0100	Texas 1330 Post & Paddock St., Suite 800 Grand Prairie, TX 75050 (945) 202-2700
---	---	--

monarchmetal.com

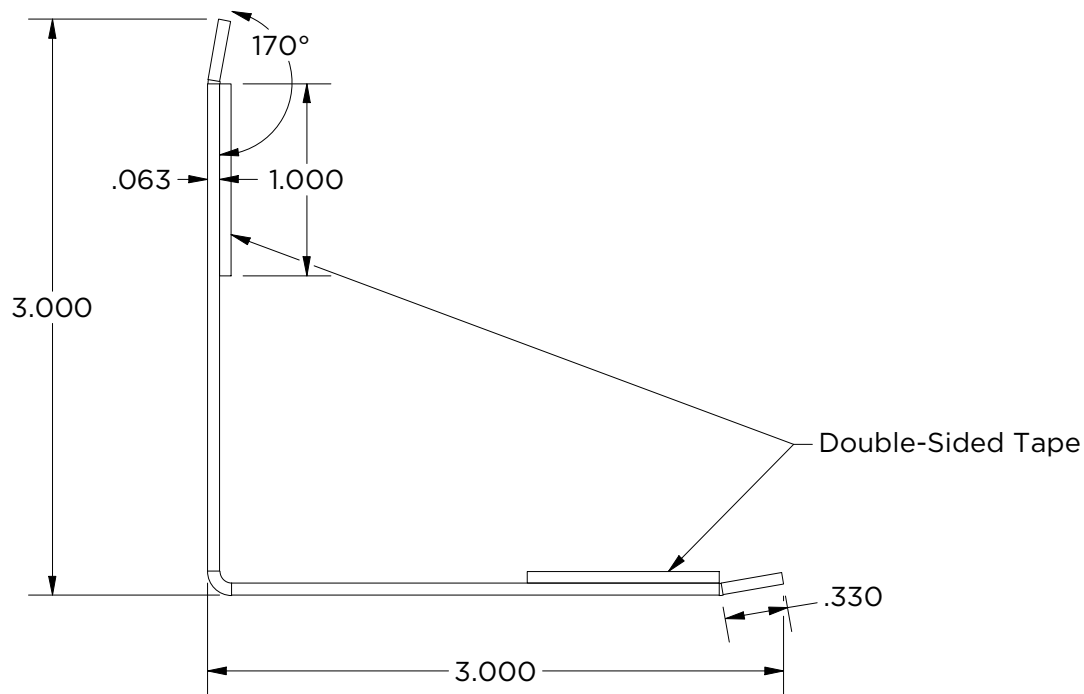

Created By: amh	Approved By:	Sheet Size A	Sheet No. 8/9
Creation Date: 7/25/2024	Approval Date:	Scale 1/28	Rev 2

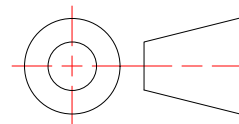

MCG-3-92T-CB

Weight: 9.799 lbmass
Stainless Steel
Finish: #4 Brushed



MONARCH
METAL INC.

PROPRIETARY AND CONFIDENTIAL

THE INFORMATION CONTAINED IN THIS DRAWING IS THE SOLE PROPERTY OF MONARCH METAL FABRICATION. ANY REPRODUCTION IN PART OR AS A WHOLE WITHOUT THE WRITTEN PERMISSION OF MONARCH METAL INC. IS PROHIBITED.

New York
1700 Ocean Ave Suite 2
Ronkonkoma NY 11779
Phone: (631) 750-3000

Nevada
1080 Linda Way, Unit 10
Sparks, NV 89431
Phone: (775) 415-0100

Texas
1330 Post & Paddock St.,
Suite 800
Grand Prairie, TX 75050
(945) 202-2700

monarchmetal.com

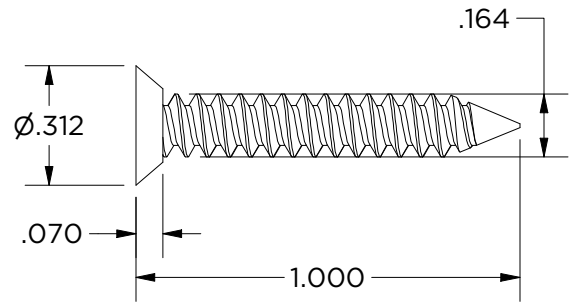
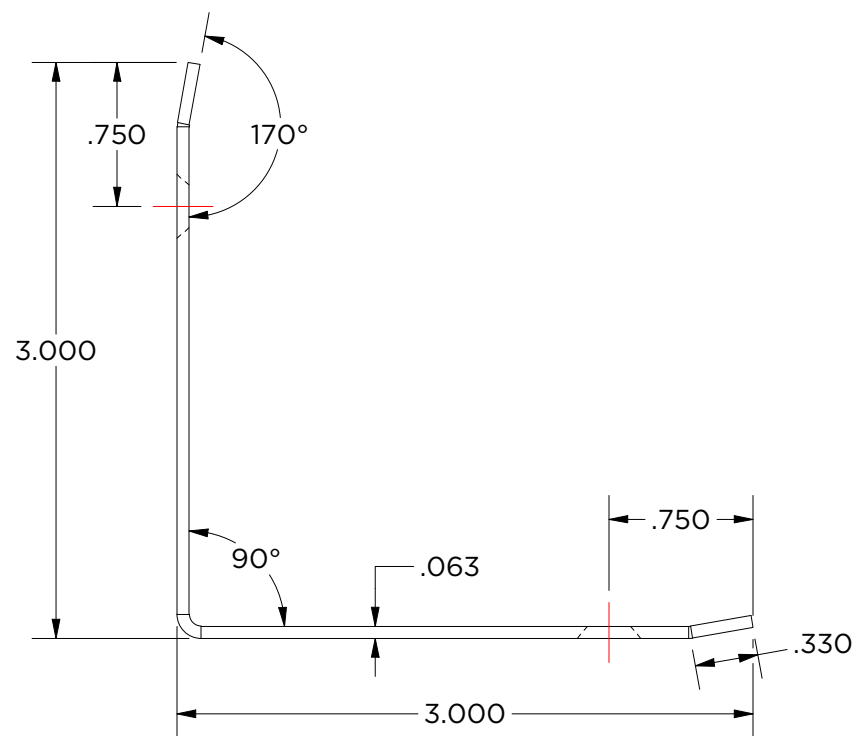
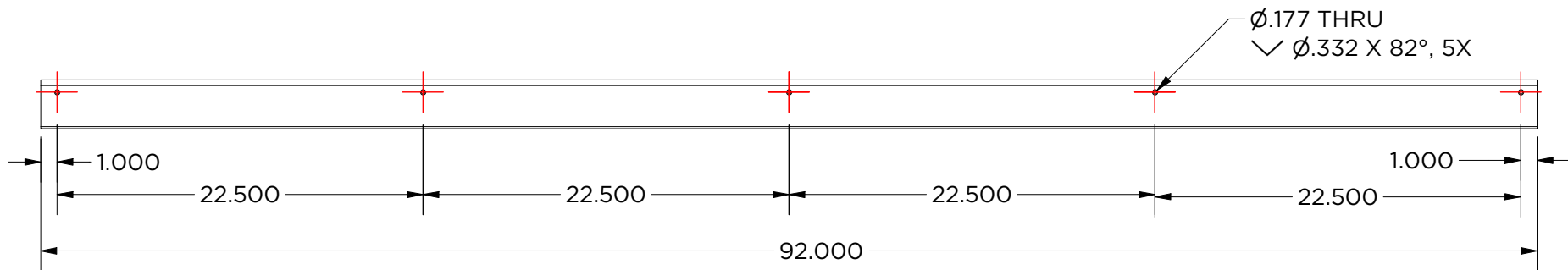

18-8 Stainless Undercut #8x1 Screw
QTY (10)

Created By: amh	Approved By:	Sheet Size A	Sheet No. 9/9
Creation Date: 7/25/2024	Approval Date:	Scale 1:1	Rev 2

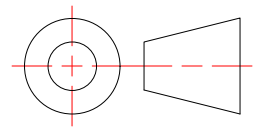

MCG-3-92H-CB

Weight: 9.788 lbmass
Stainless Steel
Finish: #4 Brushed



MONARCH
METAL INC.

PROPRIETARY AND CONFIDENTIAL
THE INFORMATION CONTAINED IN THIS DRAWING IS THE SOLE PROPERTY OF MONARCH METAL FABRICATION. ANY REPRODUCTION IN PART OR AS A WHOLE WITHOUT THE WRITTEN PERMISSION OF MONARCH METAL INC. IS PROHIBITED.

New York 1700 Ocean Ave Suite 2 Ronkonkoma NY 11779 Phone: (631) 750-3000	Nevada 1080 Linda Way, Unit 10 Sparks, NV 89431 Phone: (775) 415-0100	Texas 1330 Post & Paddock St., Suite 800 Grand Prairie, TX 75050 (945) 202-2700
---	---	--

monarchmetal.com