

Created By: Aaron Hawkins	Approved By: A.Hawkins	Sheet Size A	Sheet No. 1/11
Creation Date: 7/3/2024	Approval Date: 12/15/2025	Scale 1:6	Rev 2

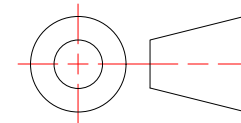

MFTP System

Hanging System and Trims for Trespa Pura NFC Planks

Weight: N/A

Finish:



MONARCH
METAL INC.

PROPRIETARY AND CONFIDENTIAL

THE INFORMATION CONTAINED IN THIS DRAWING IS THE SOLE PROPERTY OF MONARCH METAL FABRICATION. ANY REPRODUCTION IN PART OR AS A WHOLE WITHOUT THE WRITTEN PERMISSION OF MONARCH METAL INC. IS PROHIBITED.

New York
1700 Ocean Ave Suite 2
Ronkonkoma NY 11779
Phone: (631) 750-3000

Nevada
1080 Linda Way, Unit 10
Sparks, NV 89431
Phone: (775) 415-0100

Texas
1330 Post & Paddock St.,
Suite 800
Grand Prairie, TX 75050
(945) 202-2700

monarchmetal.com

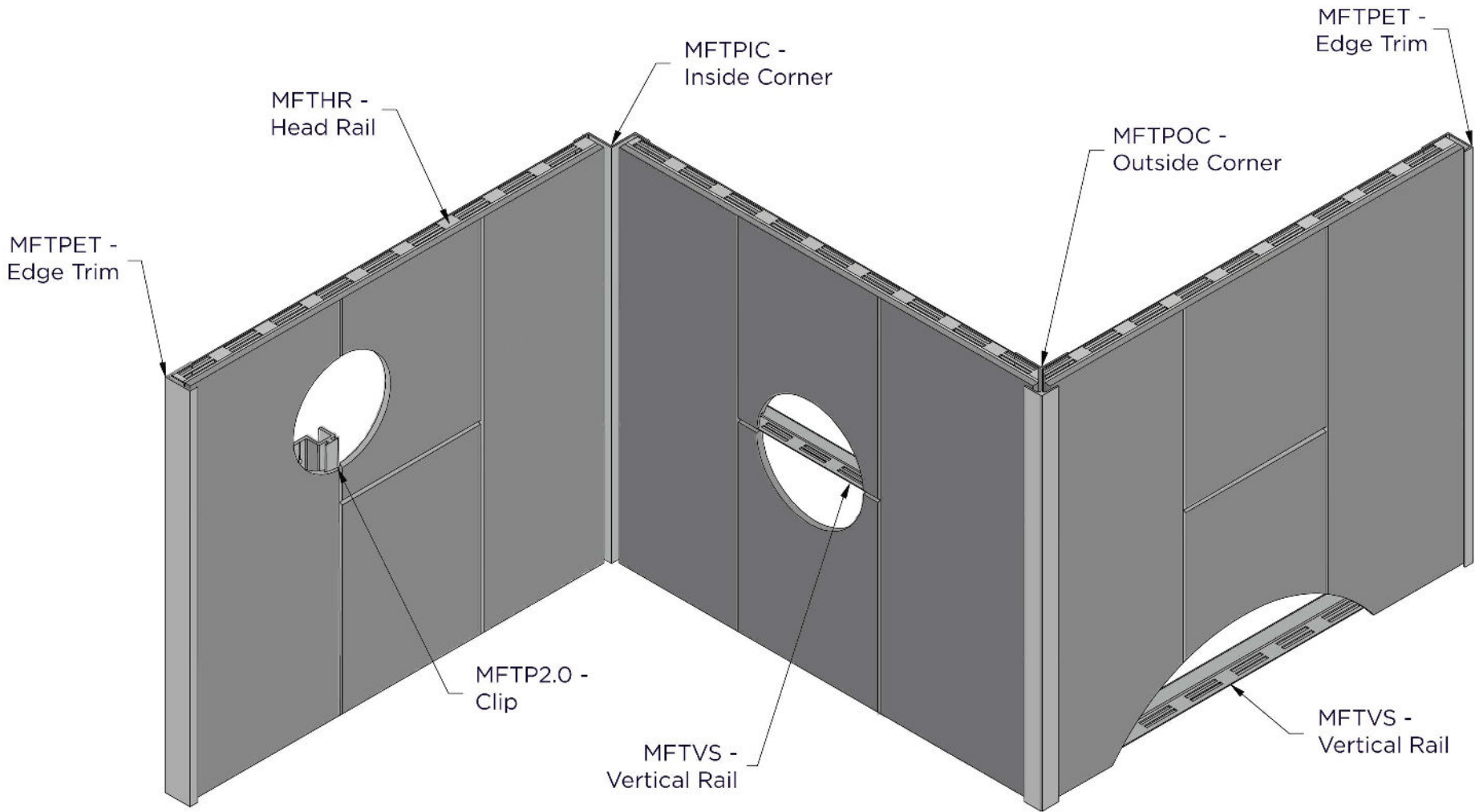

Created By: Aaron Hawkins	Approved By: A.Hawkins	Sheet Size A	Sheet No. 1/11
Creation Date: 7/3/2024	Approval Date: 12/15/2025	Scale 1:6	Rev 2

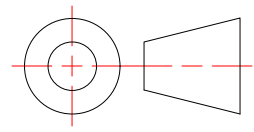

MFTP System

Hanging System and Trims for Trespa Pura NFC Planks

Weight: N/A

Finish:



MONARCH
METAL INC.

PROPRIETARY AND CONFIDENTIAL

THE INFORMATION CONTAINED IN THIS DRAWING IS THE SOLE PROPERTY OF MONARCH METAL FABRICATION. ANY REPRODUCTION IN PART OR AS A WHOLE WITHOUT THE WRITTEN PERMISSION OF MONARCH METAL INC. IS PROHIBITED.

New York
1700 Ocean Ave Suite 2
Ronkonkoma NY 11779
Phone: (631) 750-3000

Nevada
1080 Linda Way, Unit 10
Sparks, NV 89431
Phone: (775) 415-0100

Texas
1330 Post & Paddock St.,
Suite 800
Grand Prairie, TX 75050
(945) 202-2700

monarchmetal.com

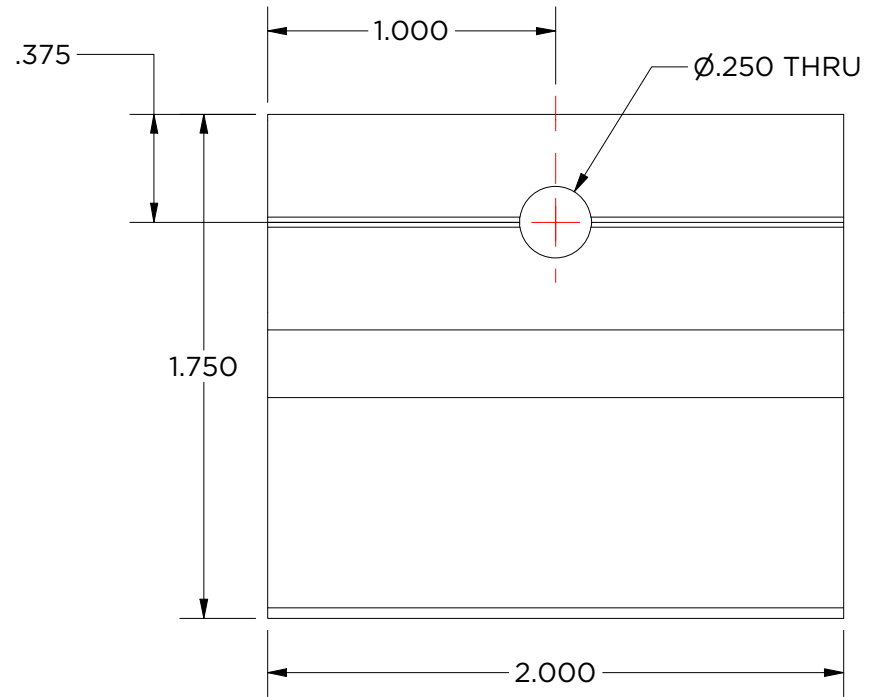
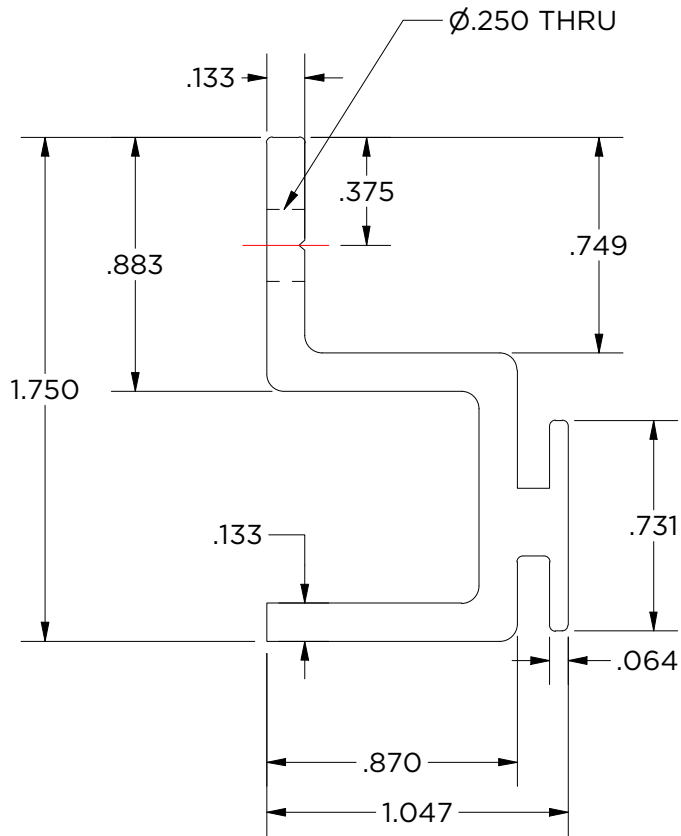

Created By: Aaron Hawkins	Approved By: A.Hawkins	Sheet Size A	Sheet No. 2/11
Creation Date: 7/3/2024	Approval Date: 12/15/2025	Scale 1.5 : 1	Rev 2

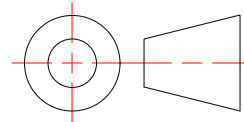

MFTP-2
Cladding Clip for Trespa Pura NFC Planks

Weight: 0.097 lbmass
Aluminum 6063
Finish: Mill



MONARCH
METAL INC.

PROPRIETARY AND CONFIDENTIAL

THE INFORMATION CONTAINED IN THIS DRAWING IS THE SOLE PROPERTY OF MONARCH METAL FABRICATION. ANY REPRODUCTION IN PART OR AS A WHOLE WITHOUT THE WRITTEN PERMISSION OF MONARCH METAL INC. IS PROHIBITED.

New York
1700 Ocean Ave Suite 2
Ronkonkoma NY 11779
Phone: (631) 750-3000

Nevada
1080 Linda Way, Unit 10
Sparks, NV 89431
Phone: (775) 415-0100

Texas
1330 Post & Paddock St.,
Suite 800
Grand Prairie, TX 75050
(945) 202-2700

monarchmetal.com

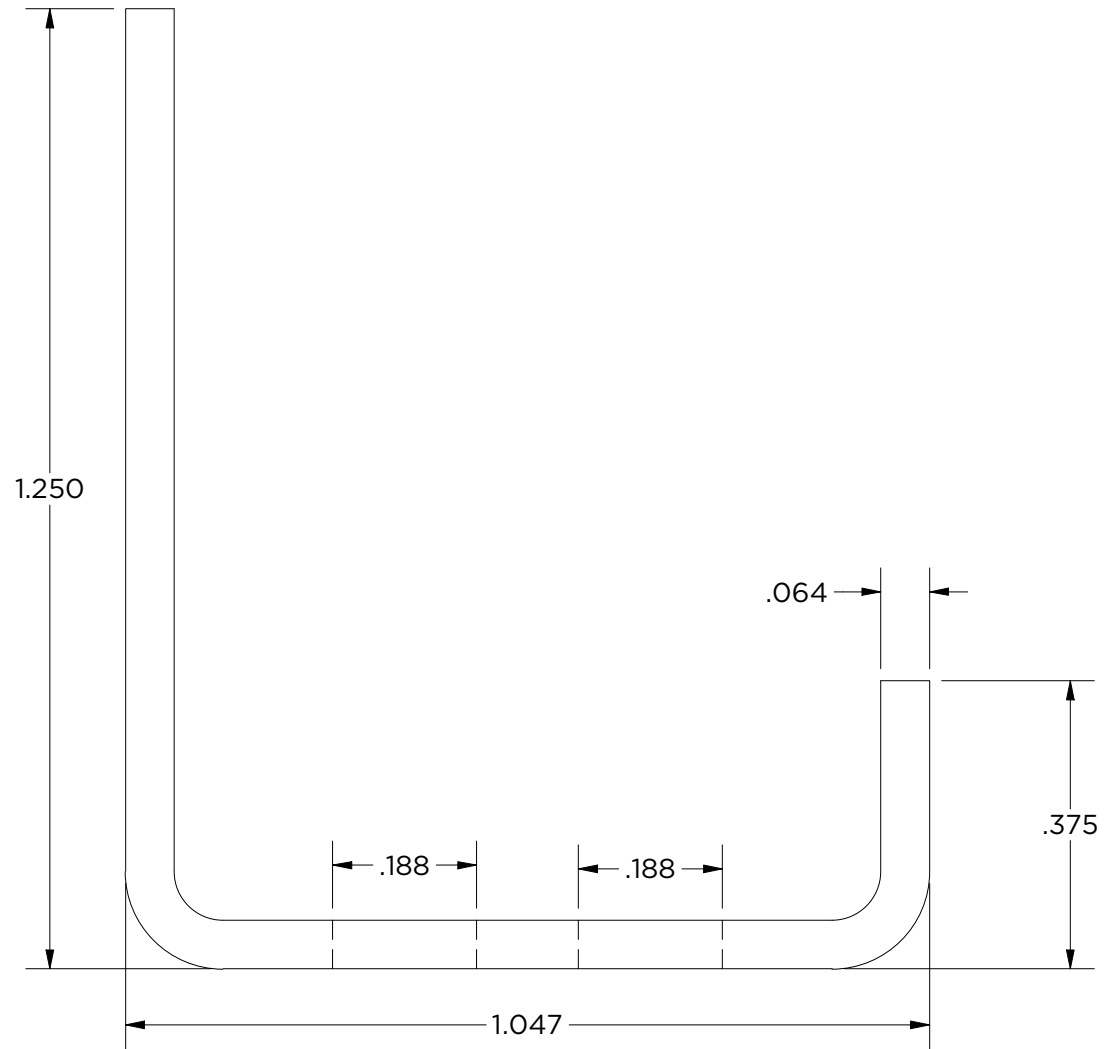

Created By: Aaron Hawkins	Approved By: A.Hawkins	Sheet Size A	Sheet No. 3/11
Creation Date: 7/3/2024	Approval Date: 12/15/2025	Scale 4 : 1	Rev 2

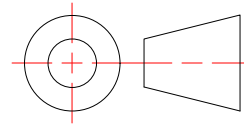

MFTPSR-120-BP

Starter Rail for Trespa Pura NFC Planks, (45) pairs of .1875x1.75" Slots

Weight: 1.666 lbmass
Aluminum 3003-H12
Finish: Black Painted



MONARCH
METAL INC.

PROPRIETARY AND CONFIDENTIAL

THE INFORMATION CONTAINED IN THIS DRAWING IS THE SOLE PROPERTY OF MONARCH METAL FABRICATION. ANY REPRODUCTION IN PART OR AS A WHOLE WITHOUT THE WRITTEN PERMISSION OF MONARCH METAL INC. IS PROHIBITED.

New York
1700 Ocean Ave Suite 2
Ronkonkoma NY 11779
Phone: (631) 750-3000

Nevada
1080 Linda Way, Unit 10
Sparks, NV 89431
Phone: (775) 415-0100

Texas
1330 Post & Paddock St.,
Suite 800
Grand Prairie, TX 75050
(945) 202-2700

monarchmetal.com

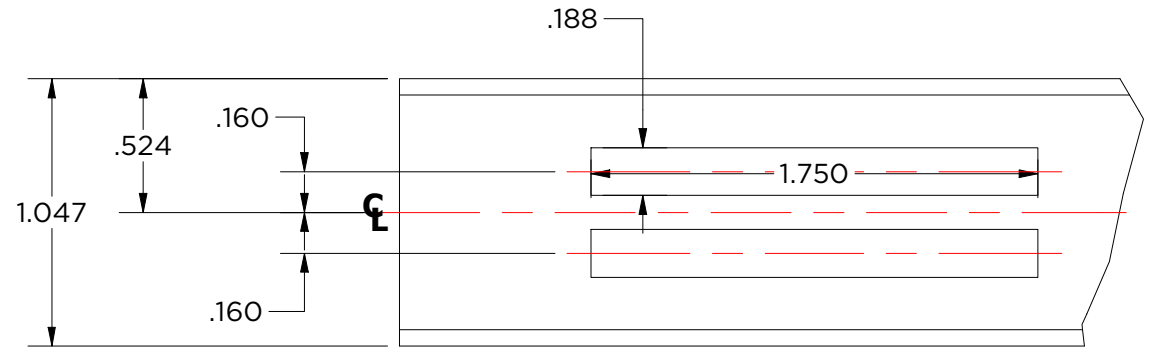

DETAIL P
SCALE 1.33 : 1

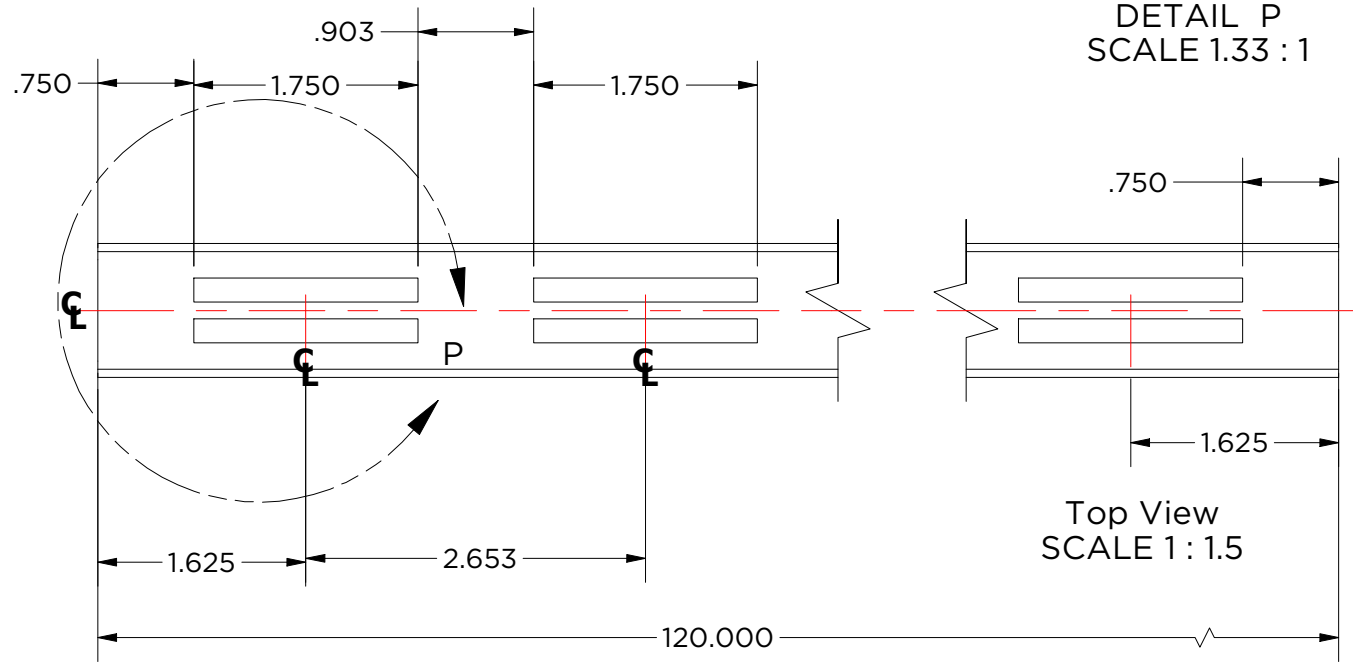

Top View
SCALE 1 : 1.5

Created By:
Aaron Hawkins

Approved By:
A.Hawkins

Sheet Size
A

Sheet No.
4/11

Creation Date:
7/3/2024

Approval Date:
12/15/2025

Scale
1 : 1.5

Rev
2

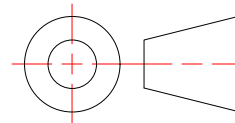

MFTPSR-120-BP

Starter Rail for Trespa Pura NFC Planks, (45) pairs of .1875x1.75" Slots

Weight: 1.666 lbmass
Aluminum 3003-H12
Finish: Black Painted



MONARCH
METAL INC.

PROPRIETARY AND CONFIDENTIAL

THE INFORMATION CONTAINED IN THIS DRAWING IS THE SOLE PROPERTY OF MONARCH METAL FABRICATION. ANY REPRODUCTION IN PART OR AS A WHOLE WITHOUT THE WRITTEN PERMISSION OF MONARCH METAL INC. IS PROHIBITED.

New York
1700 Ocean Ave Suite 2
Ronkonkoma NY 11779
Phone: (631) 750-3000

Nevada
1080 Linda Way, Unit 10
Sparks, NV 89431
Phone: (775) 415-0100

Texas
1330 Post & Paddock St.,
Suite 800
Grand Prairie, TX 75050
(945) 202-2700

monarchmetal.com

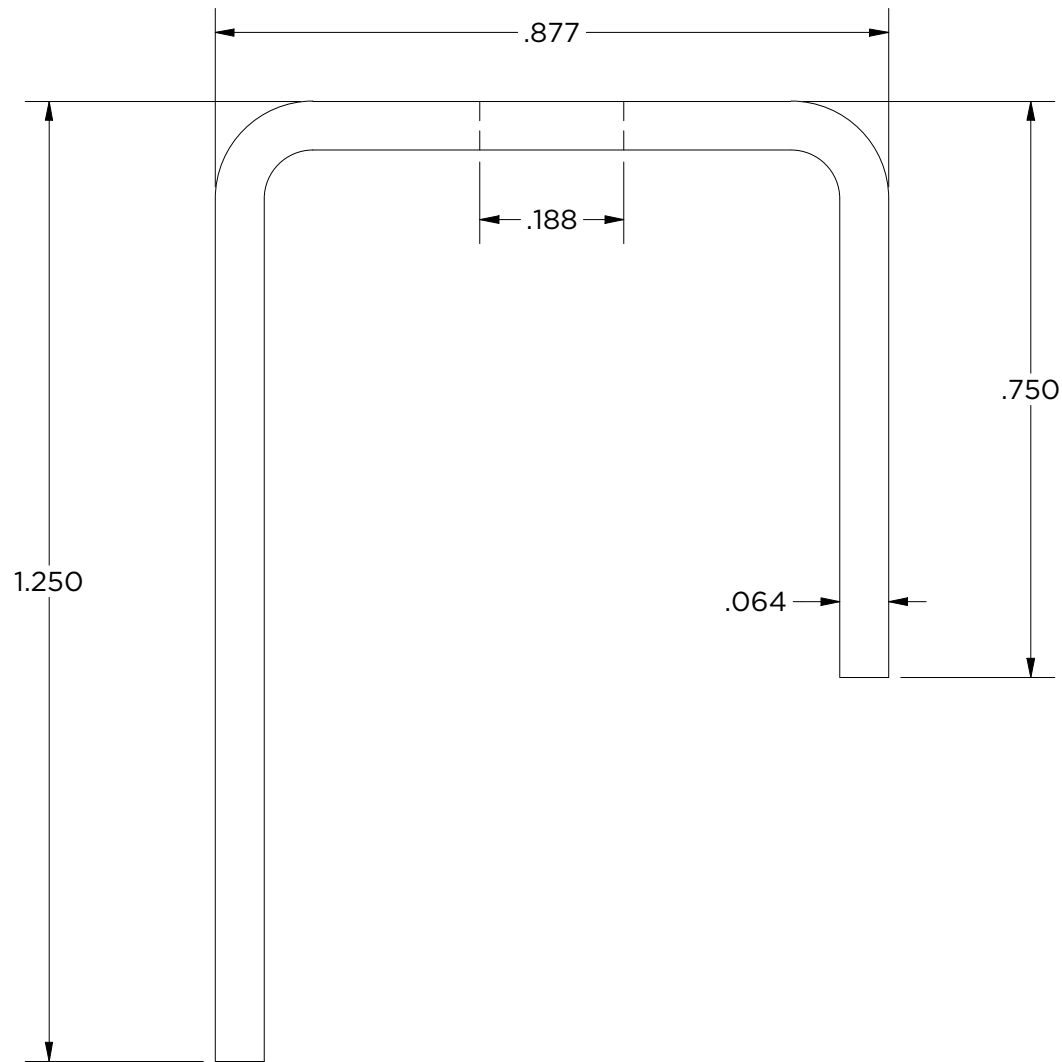

Created By: Aaron Hawkins	Approved By: A.Hawkins	Sheet Size A	Sheet No. 5/11
Creation Date: 7/3/2024	Approval Date: 12/15/2025	Scale 4 : 1	Rev 2

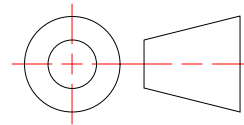

MFTPHR

Head Rail for Trespa Pura NFC Planks, (45)
.1875x1.75" Slots

Weight: 1.913 lbmass
Aluminum 3003-H12
Finish: Black Painted



MONARCH
METAL INC.

PROPRIETARY AND CONFIDENTIAL

THE INFORMATION CONTAINED IN THIS DRAWING IS THE SOLE PROPERTY OF MONARCH METAL FABRICATION. ANY REPRODUCTION IN PART OR AS A WHOLE WITHOUT THE WRITTEN PERMISSION OF MONARCH METAL INC. IS PROHIBITED.

New York
1700 Ocean Ave Suite 2
Ronkonkoma NY 11779
Phone: (631) 750-3000

Nevada
1080 Linda Way, Unit 10
Sparks, NV 89431
Phone: (775) 415-0100

Texas
1330 Post & Paddock St.,
Suite 800
Grand Prairie, TX 75050
(945) 202-2700

monarchmetal.com

DETAIL R
SCALE 2 : 1

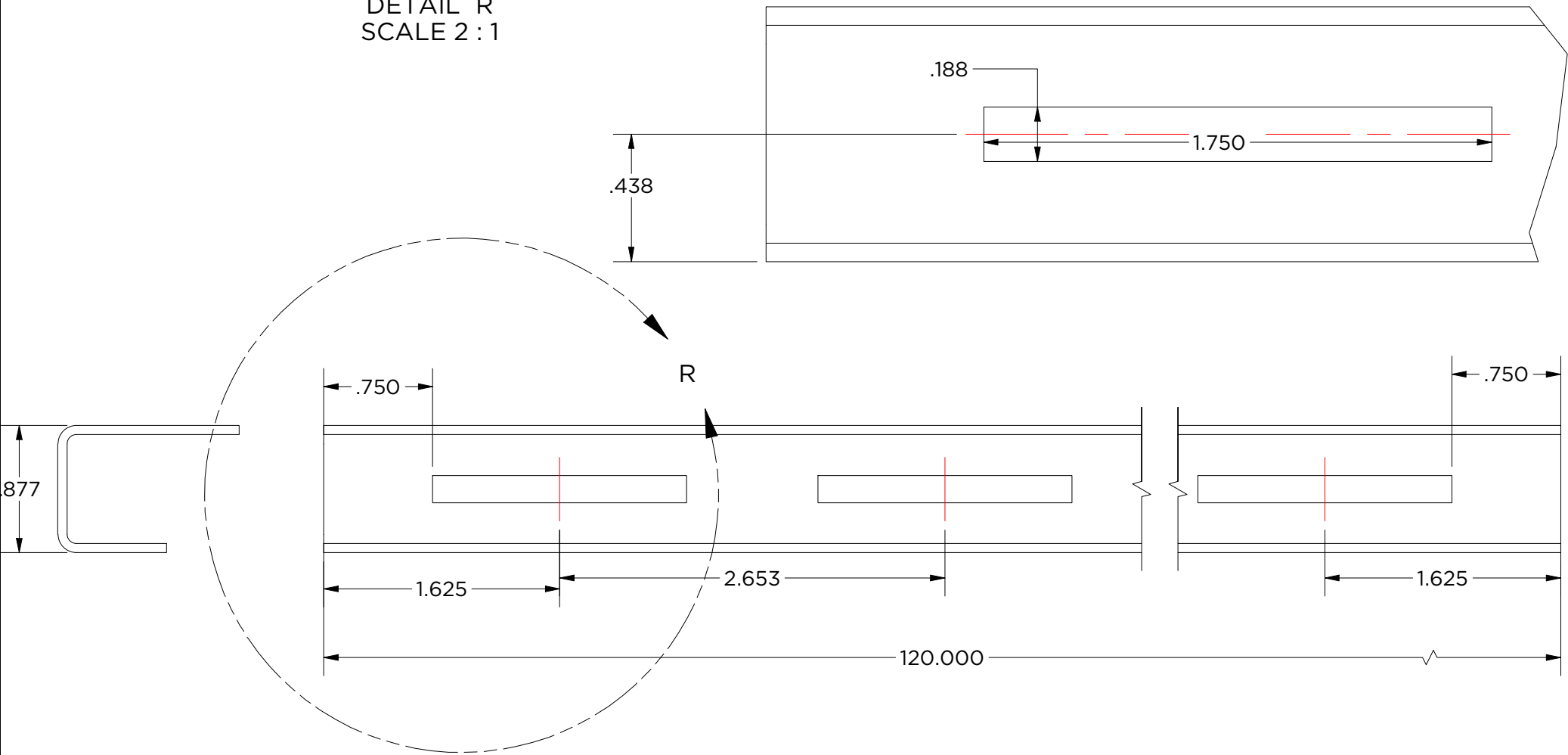

Created By: Aaron Hawkins	Approved By: A.Hawkins	Sheet Size A	Sheet No. 6/11
Creation Date: 7/3/2024	Approval Date: 12/15/2025	Scale 1 : 1	Rev 2

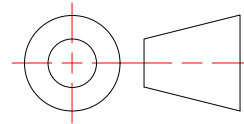

MFTPHR

Head Rail for Trespa Pura NFC Planks, (45)
.1875x1.75" Slots

Weight: 1.913 lbmass
Aluminum 3003-H12
Finish: Black Painted



MONARCH
METAL INC.

PROPRIETARY AND CONFIDENTIAL

THE INFORMATION CONTAINED IN THIS DRAWING IS THE SOLE PROPERTY OF MONARCH METAL FABRICATION. ANY REPRODUCTION IN PART OR AS A WHOLE WITHOUT THE WRITTEN PERMISSION OF MONARCH METAL INC. IS PROHIBITED.

New York
1700 Ocean Ave Suite 2
Ronkonkoma NY 11779
Phone: (631) 750-3000

Nevada
1080 Linda Way, Unit 10
Sparks, NV 89431
Phone: (775) 415-0100

Texas
1330 Post & Paddock St.,
Suite 800
Grand Prairie, TX 75050
(945) 202-2700

monarchmetal.com

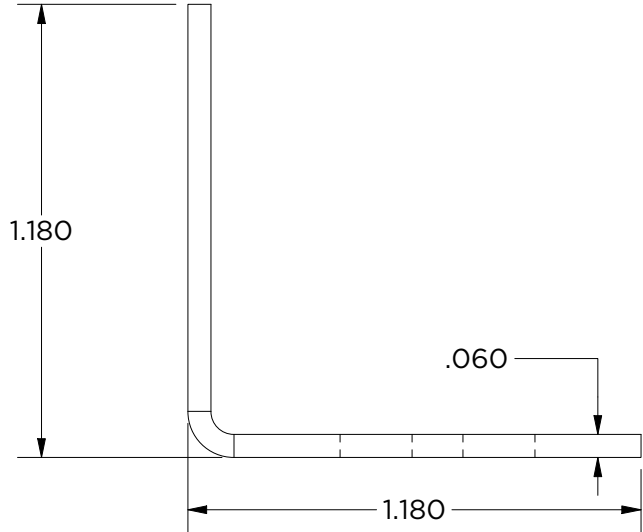
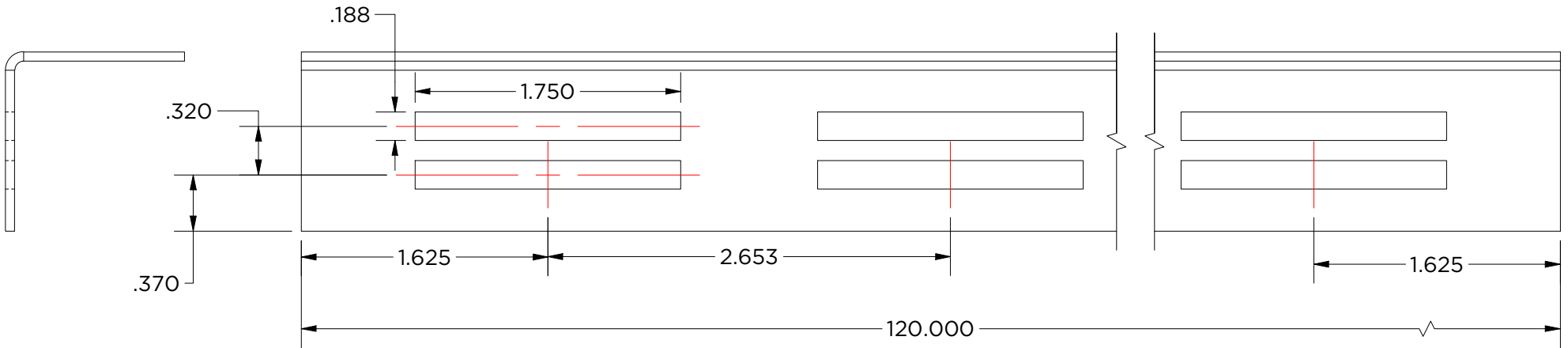

Created By: Aaron Hawkins	Approved By: A.Hawkins	Sheet Size A	Sheet No. 7/11
Creation Date: 7/3/2024	Approval Date: 12/15/2025	Scale 2 : 1	Rev 2

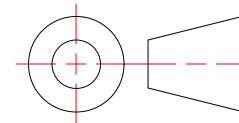

MFTPVS-120-BP

Starter Rail for Trespa Pura NFC Planks - Vertical Planks

Weight: 1.431 lbmass
Aluminum 3003-H12
Finish: Black Painted



MONARCH
METAL INC.

PROPRIETARY AND CONFIDENTIAL

THE INFORMATION CONTAINED IN THIS DRAWING IS THE SOLE PROPERTY OF MONARCH METAL FABRICATION. ANY REPRODUCTION IN PART OR AS A WHOLE WITHOUT THE WRITTEN PERMISSION OF MONARCH METAL INC. IS PROHIBITED.

New York
1700 Ocean Ave Suite 2
Ronkonkoma NY 11779
Phone: (631) 750-3000

Nevada
1080 Linda Way, Unit 10
Sparks, NV 89431
Phone: (775) 415-0100

Texas
1330 Post & Paddock St.,
Suite 800
Grand Prairie, TX 75050
(945) 202-2700

monarchmetal.com

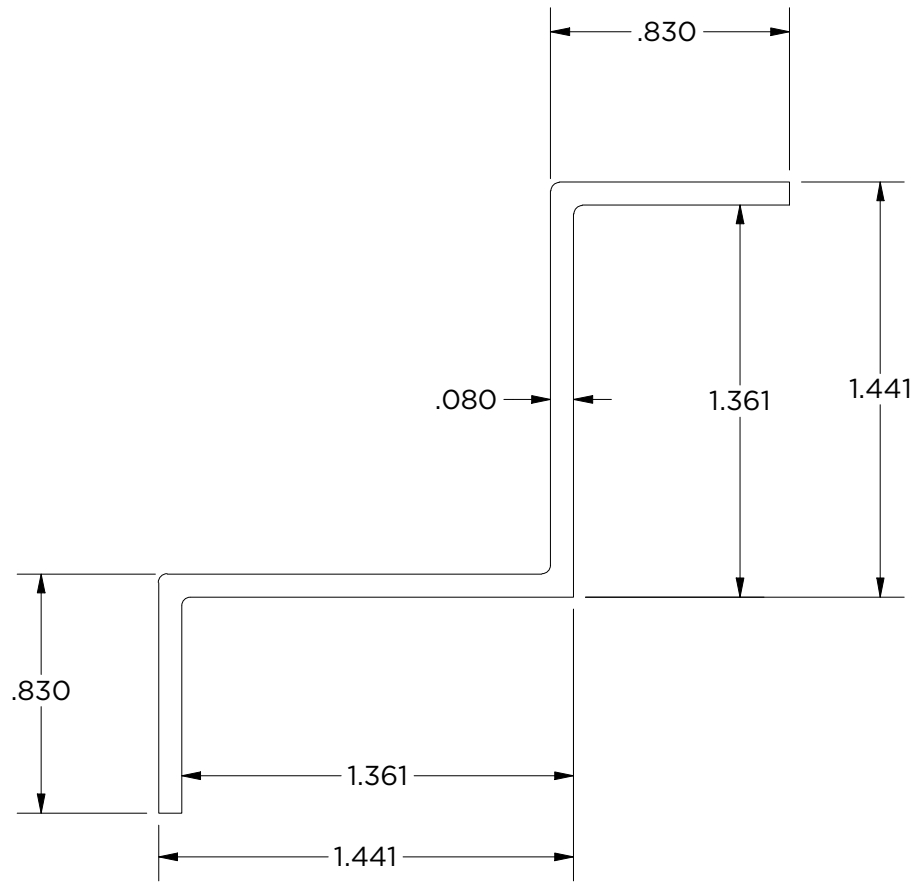

Created By: Aaron Hawkins	Approved By: A.Hawkins	Sheet Size A	Sheet No. 8/11
Creation Date: 7/3/2024	Approval Date: 12/15/2025	Scale 1.5 : 1	Rev 2

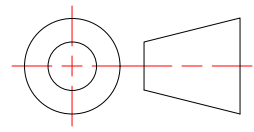

MFTPIC-120-BP

Inside Corner for Trespa Pura NFC Planks

Weight: 4.029 lbmass
Aluminum 6063
Finish: Black Powdercoat



MONARCH
METAL INC.

PROPRIETARY AND CONFIDENTIAL
THE INFORMATION CONTAINED IN THIS DRAWING IS THE SOLE PROPERTY OF MONARCH METAL FABRICATION. ANY REPRODUCTION IN PART OR AS A WHOLE WITHOUT THE WRITTEN PERMISSION OF MONARCH METAL INC. IS PROHIBITED.

New York 1700 Ocean Ave Suite 2 Ronkonkoma NY 11779 Phone: (631) 750-3000	Nevada 1080 Linda Way, Unit 10 Sparks, NV 89431 Phone: (775) 415-0100	Texas 1330 Post & Paddock St., Suite 800 Grand Prairie, TX 75050 (945) 202-2700
---	---	--

monarchmetal.com

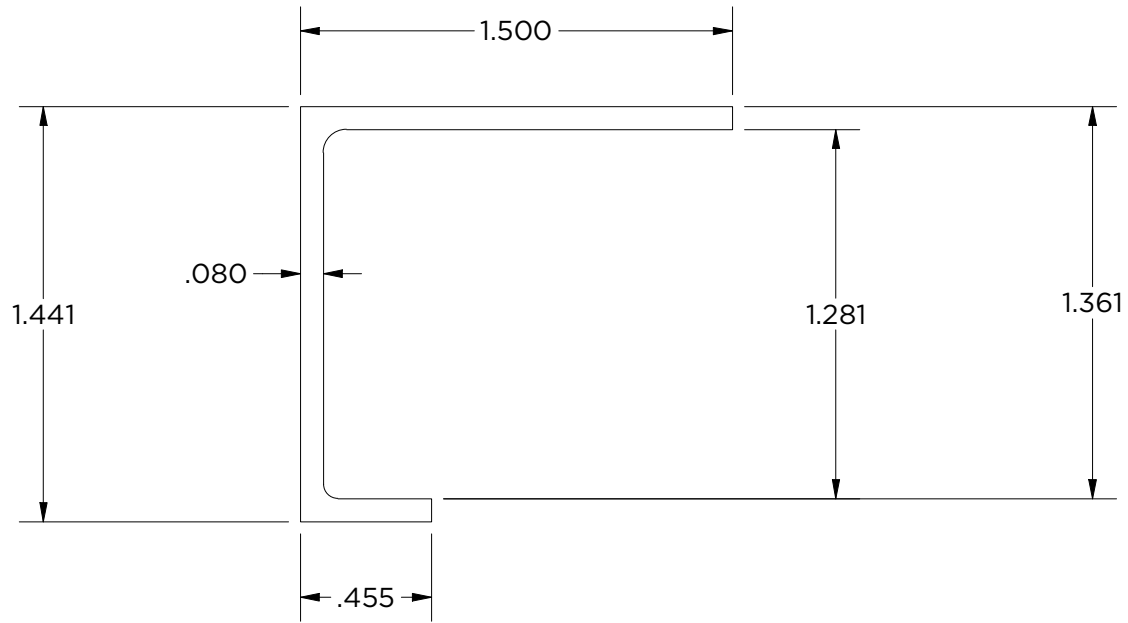

Created By: Aaron Hawkins	Approved By: A.Hawkins	Sheet Size A	Sheet No. 9/11
Creation Date: 7/3/2024	Approval Date: 12/15/2025	Scale 1.5:1	Rev 2

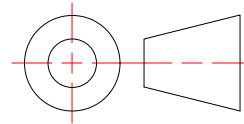

MFTPET-120-BP

Edge Trim for Trespa Pura NFC Planks

Weight: 3.051 lbmass

Aluminum 6063

Finish: Black Powdercoat



MONARCH
METAL INC.

PROPRIETARY AND CONFIDENTIAL

THE INFORMATION CONTAINED IN THIS DRAWING IS THE SOLE PROPERTY OF MONARCH METAL FABRICATION. ANY REPRODUCTION IN PART OR AS A WHOLE WITHOUT THE WRITTEN PERMISSION OF MONARCH METAL INC. IS PROHIBITED.

New York
1700 Ocean Ave Suite 2
Ronkonkoma NY 11779
Phone: (631) 750-3000

Nevada
1080 Linda Way, Unit 10
Sparks, NV 89431
Phone: (775) 415-0100

Texas
1330 Post & Paddock St.,
Suite 800
Grand Prairie, TX 75050
(945) 202-2700

monarchmetal.com

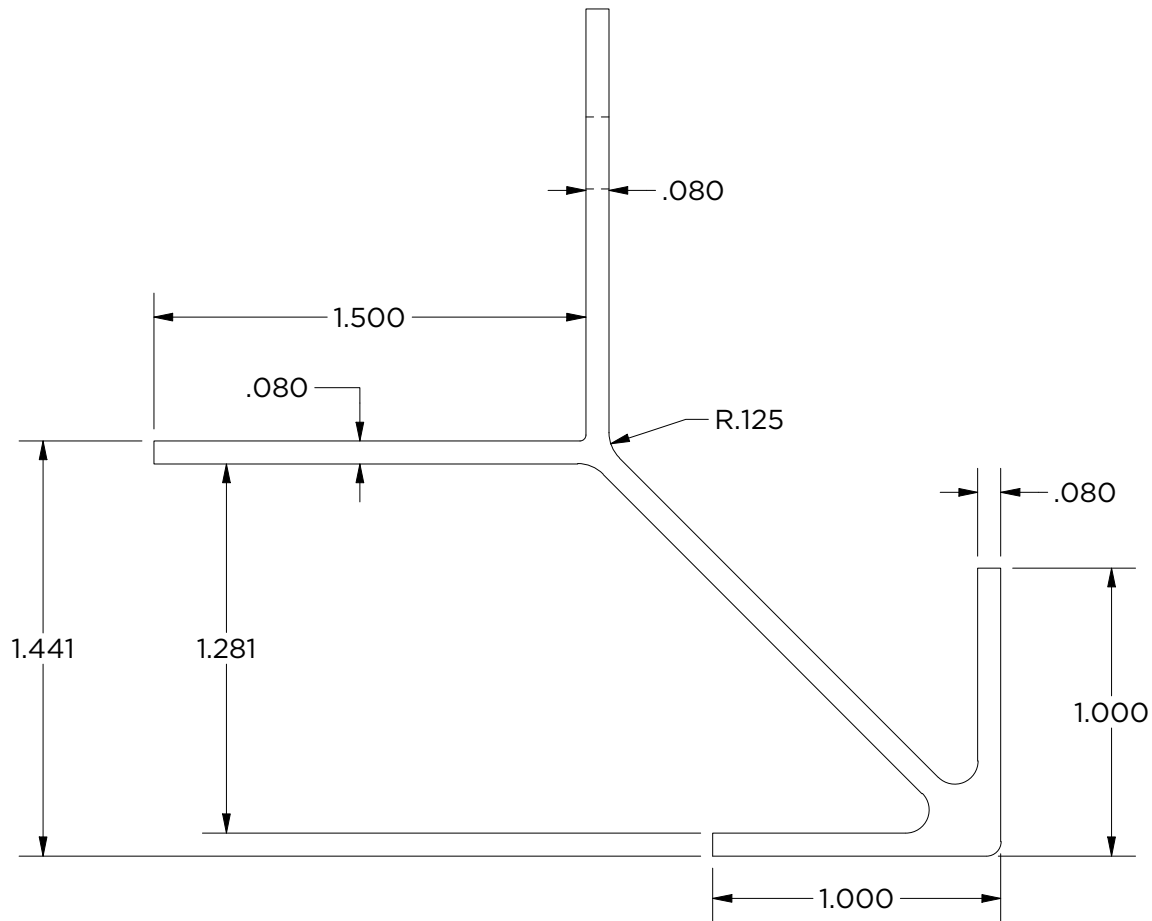

Created By: Aaron Hawkins	Approved By: A.Hawkins	Sheet Size A	Sheet No. 10/11
Creation Date: 7/3/2024	Approval Date: 12/15/2025	Scale 1.5:1	Rev 2

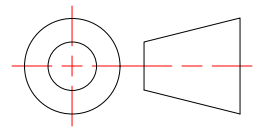

MFTPOC-120-BP

Outside Corner for Trespa Pura NFC Planks

Weight: 6.563 lbmass
Aluminum 6063
Finish: Black Powdercoat



MONARCH
METAL INC.

PROPRIETARY AND CONFIDENTIAL

THE INFORMATION CONTAINED IN THIS DRAWING IS THE SOLE PROPERTY OF MONARCH METAL FABRICATION. ANY REPRODUCTION IN PART OR AS A WHOLE WITHOUT THE WRITTEN PERMISSION OF MONARCH METAL INC. IS PROHIBITED.

New York
1700 Ocean Ave Suite 2
Ronkonkoma NY 11779
Phone: (631) 750-3000

Nevada
1080 Linda Way, Unit 10
Sparks, NV 89431
Phone: (775) 415-0100

Texas
1330 Post & Paddock St.,
Suite 800
Grand Prairie, TX 75050
(945) 202-2700

monarchmetal.com

